

Gas filters GFK

Technical Information · GB
1 Edition 06.14l

- For the protection of downstream devices against blockage
- Very high throughput
- High purification efficiency
- Long service life
- Easy-to-replace filter pad
- EC type-tested and certified

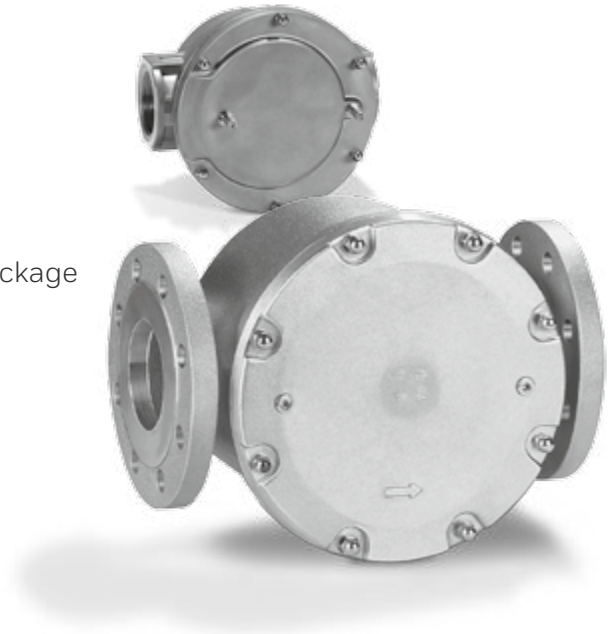

Contents

Gas filters GFK	1
Contents	2
1 Application	3
1.1 Examples of application	4
2 Certification	5
3 Function	6
3.1 Animation	7
4 Flow rate	8
4.1 Calculating the nominal size	8
5 Selection	9
5.1 Standard range	9
5.2 T-products range	9
5.3 Type code	9
6 Project planning information	10
6.1 Installation	10
7 Accessories	11
7.1 Filter pads with a separation rate of 50 µm	11
7.2 Filter pads with a special separation rate of 10 µm	11
8 Technical data	12
8.1 Dimensions	13
8.1.1 GFK 15 to 250	13
8.1.2 GFK 15T to 100T	14
9 Maintenance cycles	15
Feedback	16
Contact	16

1 Application



GFK..R

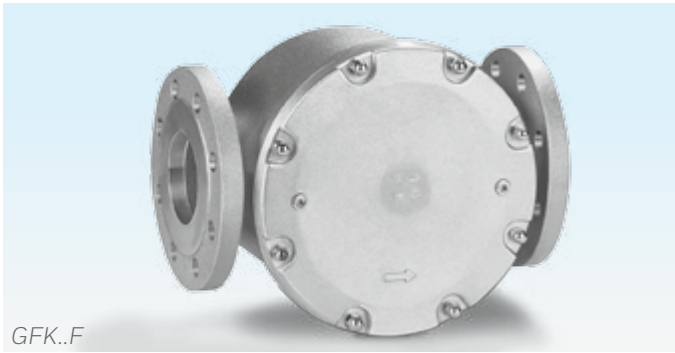

GFK..F

Suitable for filtration of the fuel gas and combustion air supply to all gas consuming appliances.

1.1 Examples of application

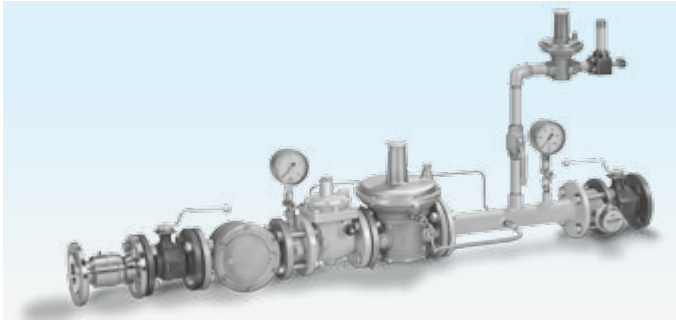

Gas pressure control system with GFK..F

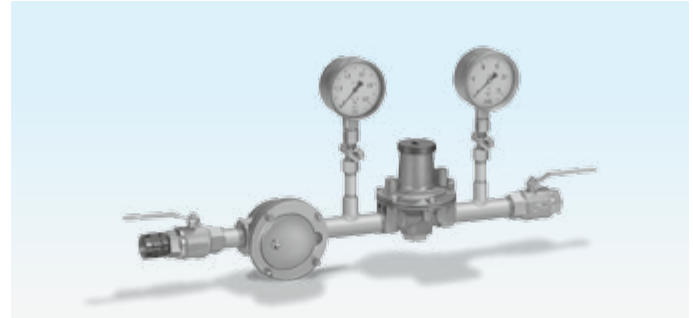

Pressure control system with GFK..R

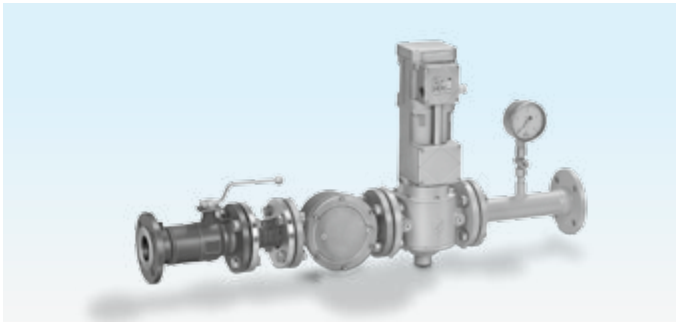

Main gas shut-off device with GFK..F

2 Certification

EC type-tested and certified

pursuant to:



– Gas Appliances Directive (2009/142/EC)

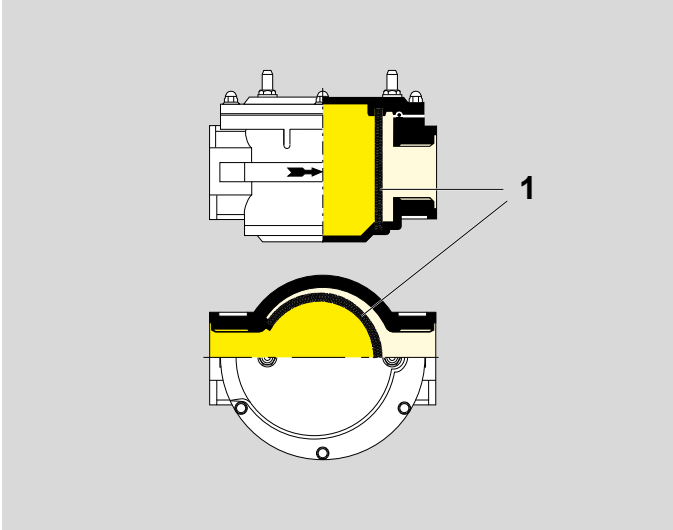

3 Function

Gas filter GFK is used for cleaning fuel gases and air.

With clean filter pad **1** with a standard separation rate of 50 μm , the pressure gradient over the filter pad must not exceed 10 mbar (4 "WC).

The pressure gradient will increase with soiling due to the gas. The filter pad must be changed at a pressure gradient ≥ 20 mbar (8 "WC), see operating instructions. Otherwise, dust may be forced through the pad.

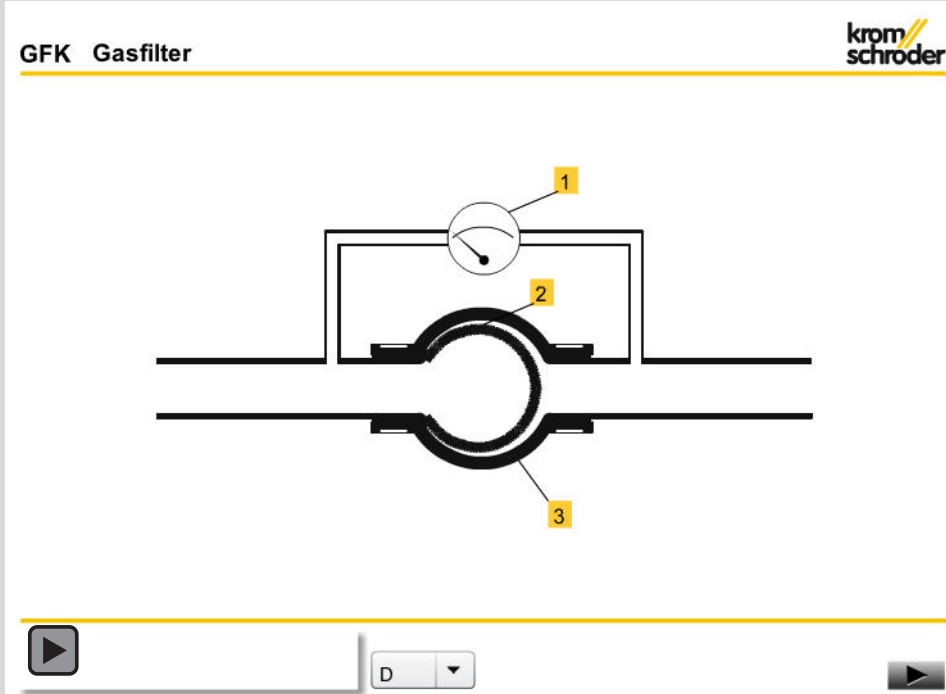

3.1 Animation

The interactive animation shows the function of the gas filter GFK.

Click on the picture. The animation can be controlled using the control bar at the bottom of the window (as on a DVD player).

To play the animation, you will need Adobe Reader 9 or a newer version. If you do not have Adobe Reader on your system, you can download it from the Internet.

If the animation does not start to play, you can download it from the document library (Docuthek) as an independent application.

4 Flow rate

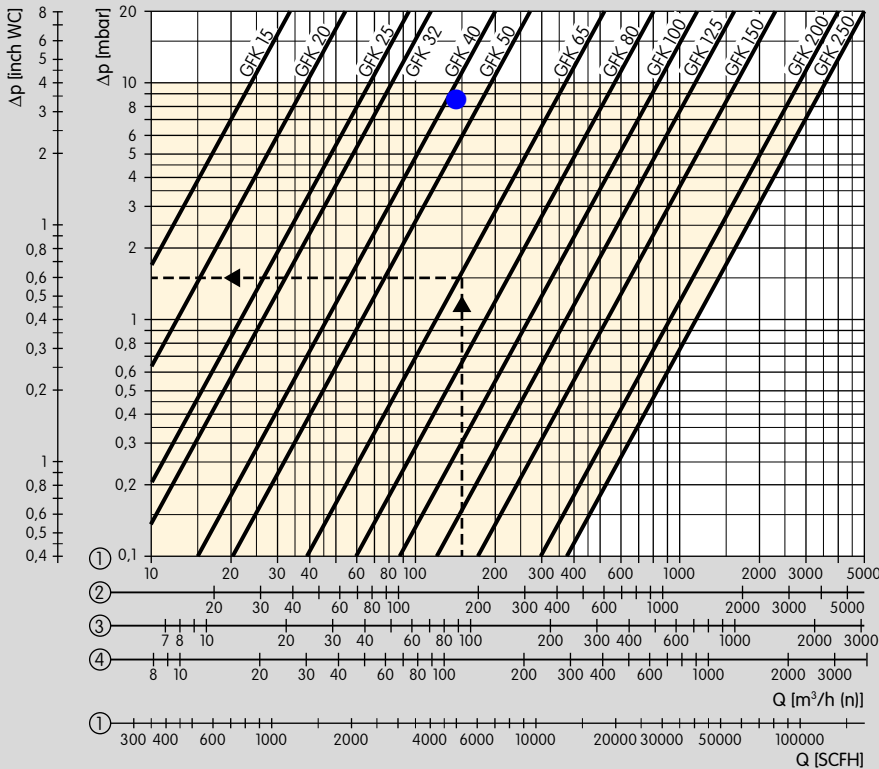

- ① = natural gas ($\rho = 0.80 \text{ kg/m}^3$)
- ② = town gas ($\rho = 0.58 \text{ kg/m}^3$)
- ③ = propane ($\rho = 2.01 \text{ kg/m}^3$)
- ④ = air ($\rho = 1.29 \text{ kg/m}^3$)

A pressure loss of 10 mbar must not be exceeded.

Reading instructions:
When determining the pressure loss, operating cubic metres must be entered. Then the pressure loss Δp read must be multiplied by the absolute pressure in bar (positive pressure + 1) to account for the change in the medium's density.
Example:
inlet pressure p_u (positive pressure) = 4 bar,
gas type: natural gas,
operating flow rate $Q_b = 150 \text{ m}^3/\text{h}$ (b),
selected filter: GFK 65,
 Δp in the diagram = 1.5 mbar,
 $\Delta p = 1.5 \text{ mbar} \times (1 + 4) = 7.5 \text{ mbar}$.
The GFK 65 has been selected correctly.

4.1 Calculating the nominal size

- Standard
- T-product

Natural gas	0.80	kg/m ³
Flow rate Q (standard)	740	m ³ /h
Inlet pressure p_u	4000	mbar
Δp_{max}	10.0	mbar
Medium temperature	0	°C
Flow rate Q (operation)	150	m ³ /h

Product	Δp [mbar]	v [m/s]
GFK 65	7.5	11
GFK 80	3.2	8
GFK 100	1.5	5
GFK 125	0.8	3
GFK 150	0.4	2
GFK 200	0.1	1
GFK 250	0.1	1

5 Selection

5.1 Standard range

	10	40	60	-3	-6
GFK 15R	●	●			●
GFK 20R	●	●			●
GFK 25R	●	●			●
GFK 32R	●	●			●
GFK 40R	●	●			●
GFK 50R	●	●			●
GFK 65R	●	●			●
GFK 40F	●		●		●
GFK 50F	●		●		●
GFK 65F	●		●		●
GFK 80F	●		●		●
GFK 100F	●		●		●
GFK 125F	●	●		●	
GFK 150F	●	●		●	
GFK 200F	●			●	
GFK 250F	●			●	

Order example

GFK 32R10-6

5.2 T-products range

	N	A	40	-3
GFK 15T	●		●	●
GFK 20T	●		●	●
GFK 25T	●		●	●
GFK 40T	●		●	●
GFK 50T	●	●	●	●
GFK 65T	●	●	●	●
GFK 80T		●	●	●
GFK 100T		●	●	●

Order example

GFK 40TN40-3

5.3 Type code

Code	Description
GFK	Gas filter
15, 20, 25, 32, 40, 50, 65, 80, 100, 125, 150, 200, 250	Nominal size
T	T-product
R F N A	Rp internal thread Flanged connection to ISO 7005 NPT internal thread ANSI flange
10 40 60	Max. inlet pressure $p_{U,max}$ 1 bar 4 bar (58 psig) 6 bar
-3 -6	Screw plug at the inlet and outlet Pressure test point at the inlet and outlet

6 Project planning information

6.1 Installation

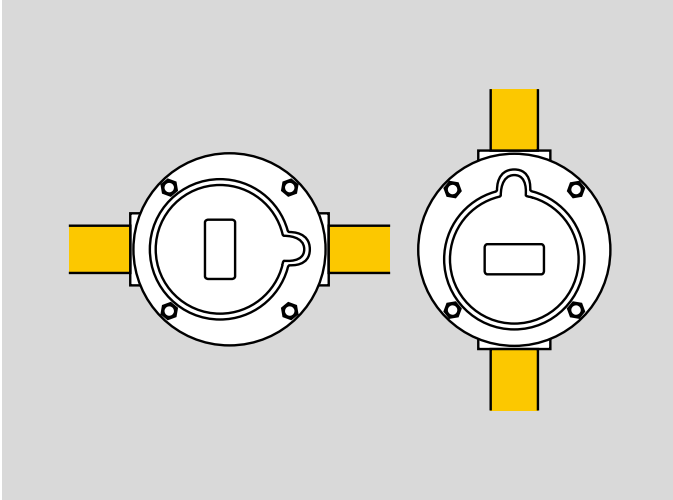

Installation in horizontal and vertical pipework.

The housing cover should be detachable at the side so that no dirt gets into the housing during maintenance.

7 Accessories

7.1 Filter pads with a separation rate of 50 µm

Spare parts set GFK 15/20, 10 filter pads and 10 O-rings: Order No.: 71935010.

Spare parts set GFK 25/32, 10 filter pads and 10 O-rings: Order No.: 71937010.

Spare parts set GFK 40/50, 5 filter pads and 5 O-rings: Order No.: 71939010.

Spare parts set GFK 65, 1 filter pad and 1 O-ring: Order No.: 74923284.

Spare parts set GFK 80, 1 filter pad and 1 O-ring: Order No.: 74923285.

Spare parts set GFK 100, 1 filter pad and 1 O-ring: Order No.: 74923286.

Filter pad GFK 125: Order No.: 35448581.

O-ring 308x8 for GFK 125/150: Order No.: 03110013.

Filter pad GFK 150: Order No.: 35448583.

O-ring 308x8 for GFK 125/150: Order No.: 03110013.

Filter pad GFK 200/250: Order No.: 35448584.

O-ring 430x8 for GFK 200/250: Order No.: 03109164.

7.2 Filter pads with a special separation rate of 10 µm

For air or inert gases only.

Spare parts set GFK 15+20R40-S10: 10 filter pads and 10 O-rings: Order No.: 74919810.

Spare parts set GFK 25+32R40-S10: 10 filter pads and 10 O-rings: Order No.: 74919811.

Spare parts set GFK 40+50F40-S10: 5 filter pads and 5 O-rings: Order No.: 74919812.

Spare parts set GFK 65..S10: 1 filter pad and 1 O-ring: Order No.: 74923281.

Spare parts set GFK 80..S10: 1 filter pad and 1 O-ring: Order No.: 74923282.

Spare parts set GFK 100..S10: 1 filter pad and 1 O-ring: Order No.: 74923283.

8 Technical data

Gas type:

natural gas, town gas, LPG (gaseous), biologically produced methane and air.

Max. inlet pressure p_u :

1 bar GFK 15 to 250,

4 bar (60 psig) GFK 15R to 65R, GFK 15TN to 100TN,

6 bar GFK 40F to 100F.

Ambient temperature: -15 to +80°C (5 to 176°F).

Continuous operation at high temperatures accelerates the ageing of elastomer materials.

Version to DIN 3386

Housing

GFK 15 to 100 made from AlSi.

GFK 125 to 250 made from sheet steel.

GFK..R: Rp internal thread connection to ISO 7-1.

GFK..F: flanged connection to ISO 7005, PN 16.

GFK..N: NPT internal thread.

GFK..A: ANSI 150 flanged connection.

Filter pad: polypropylene fleece (standard 50 µm).

Pressure test points on the cover

GFK 15 to 100:

Inlet side: Rp 1/8 pressure test nipple,

Outlet side: Rp 1/8 pressure test nipple.

GFK 125 to 250:

Inlet side: Rp 1/8 plug,

Outlet side: Rp 1/8 plug.

GFK 15T to 100T:

Inlet side: Rp 1/8 plug,

Outlet side: Rp 1/8 plug.

8.1 Dimensions

8.1.1 GFK 15 to 250

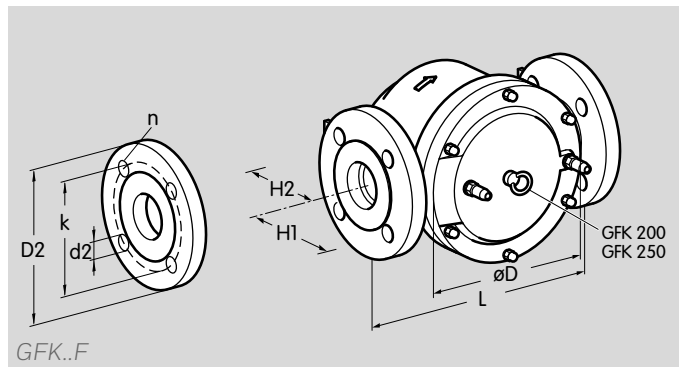
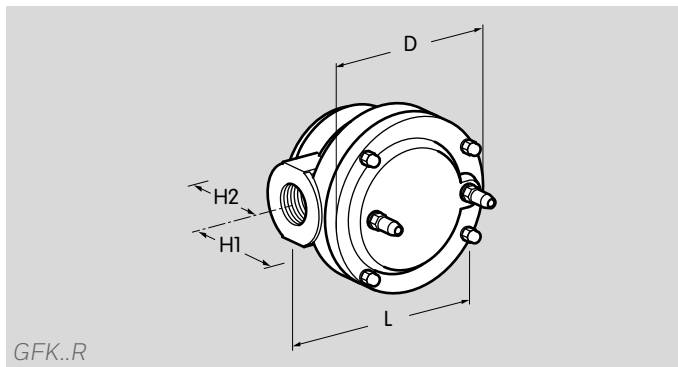

Type	Dimensions						Flange		Drilling		p _{U max.} bar	Weight kg	Filter mm x mm
	DN	Connection	L mm	D mm	H1 mm	H2 mm	D2 mm	k mm	d2 mm	No.			
GFK 15	15	Rp 1/2	92	88	69	33	-	-	-	-	1 + 4	0.4	127 x 56
GFK 20	20	Rp 3/4	92	88	69	33	-	-	-	-	1 + 4	0.4	127 x 56
GFK 25	25	Rp 1	135	134	69	43	-	-	-	-	1 + 4	0.8	210 x 75
GFK 32	32	Rp 1 1/4	135	134	69	43	-	-	-	-	1 + 4	0.8	210 x 75
GFK 40	40	Rp 1 1/2	208	182	88	64	-	-	-	-	1 + 4	2.0	323 x 114
GFK 50	50	Rp 2	208	182	88	64	-	-	-	-	1 + 4	2.0	323 x 114
GFK 65	65	Rp 2 1/2	220	182	119	96	-	-	-	-	1 + 4	3.3	323 x 177
GFK 40	40	40	256	182	88	63	150	110	18	4	1 + 6	3.9	323 x 114
GFK 50	50	50	250	182	88	63	165	125	18	4	1 + 6	4.2	323 x 114
GFK 65	65	65	250	182	118	97	185	145	18	4	1 + 6	5.5	323 x 177
GFK 80	80	80	330	262	133	87	200	160	18	8	1 + 6	9.6	489 x 177
GFK 100	100	100	350	262	137	120	228	180	18	8	1 + 6	11.5	437 x 209
GFK 125	125	125	470	355	133	125	250	210	18	8	1 + 4	45.0	675 x 226
GFK 150	150	150	470	355	181	167	285	240	23	8	1 + 4	55.0	675 x 316
GFK 200	200	200	630	500	310	202	340	295	23	12	1	120.0	908 x 417
GFK 250	250	250	630	500	310	202	355	355	27	12	1	130.0	908 x 417

8.1.2 GFK 15T to 100T

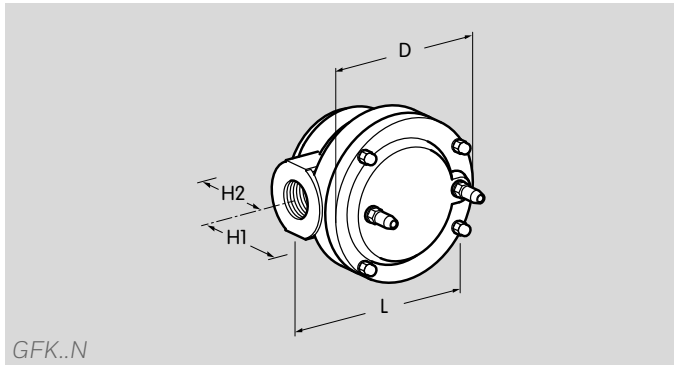

GFK..N

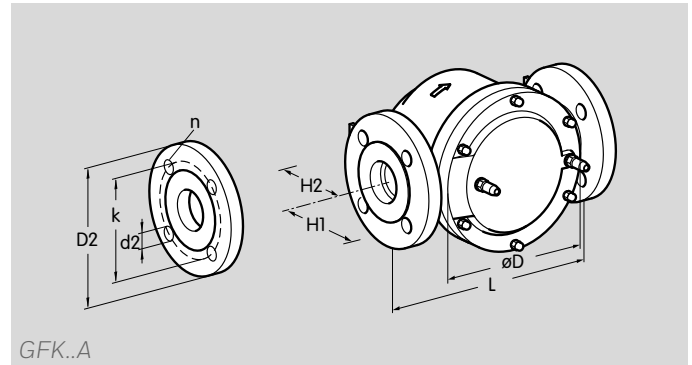

GFK..A

Type	Connection		Dimensions				ANSI 150 flange		Drilling		Weight	Filter pad
	NPT		L	D	H1	H2	D2	k	d2	No.	lbs	Dimensions
	ANSI	DN	inch	inch	inch	inch	inch	inch	inch			inch ²
GFK 15TN	½	15	3.26	3.46	2.01	1.23	-	-	-	-	0.8	9.3
GFK 20TN	¾	20	3.62	3.46	2.01	1.23	-	-	-	-	0.8	9.3
GFK 25TN	1	25	5.35	5.28	2.20	1.73	-	-	-	-	1.7	21
GFK 40TN	1½	40	8.19	5.28	2.99	2.52	-	-	-	-	4.4	52
GFK 50TN	2	50	8.19	5.28	2.99	2.52	-	-	-	-	4.9	52
GFK 65TN	2½	65	8.66	5.28	4.17	3.78	-	-	-	-	11.5	89
GFK 50TA	2	50	9.84	5.28	2.99	2.48	5.98	4.76	0.75	4	9.3	52
GFK 65TA	2½	65	9.84	5.28	4.17	3.82	7.01	5.51	0.75	4	11.5	84
GFK 80TA	3	80	13.0	10.3	4.72	3.42	7.52	5.98	0.75	4	17.6	122
GFK 100TA	4	100	13.8	10.3	4.92	4.72	9.02	7.52	0.75	8	20.5	145

9 Maintenance cycles

Change filter pad once per annum, twice per annum for biologically produced methane, or in case the pressure differential on the gas filter has risen by 100% compared to when new, $\Delta p_{\max.} = 20$ mbar.

Feedback

Finally, we are offering you the opportunity to assess this “Technical Information (TI)” and to give us your opinion, so that we can improve our documents further and suit them to your needs.

Clarity

- Found information quickly
- Searched for a long time
- Didn't find information
- What is missing?
- No answer

Comprehension

- Coherent
- Too complicated
- No answer

Scope

- Too little
- Sufficient
- Too wide
- No answer



Use

- To get to know the product
- To choose a product
- Planning
- To look for information

Navigation

- I can find my way around
- I got “lost”
- No answer

My scope of functions

- Technical department
- Sales
- No answer

Remarks



Contact

Elster GmbH
Postfach 2809 · 49018 Osnabrück
Strohweg 1 · 49504 Lotte (Büren)
Germany

Tel +49 541 1214-0
Fax +49 541 1214-370
info@kromschroeder.com
www.kromschroeder.com

The current addresses of our international agents
are available on the Internet:
www.kromschroeder.de/Weltweit.20.0.html?&L=1

We reserve the right to make technical
modifications in the interests of progress.
Copyright © 2016 Elster GmbH
All rights reserved.

