

Flow adjusting cocks GEHV, GEH, LEH

Technical Information · GB
10 Edition 08.16

- Precise adjustment of gas and air flow rates
- Various setting options using hand wheel or tools
- GEHV: accurate adjustment thanks to reduction of rotary movement



Contents

Flow adjusting cocks GEHV, GEH, LEH	1
Contents	2
1 Application	3
1.1 Examples of application	4
2 Certification	5
3 Function	6
3.1 GEHV, GEH	6
3.2 LEH	6
4 Flow rate	7
4.1 GEHV	7
4.2 GEH	8
4.3 LEH	9
5 Selection	10
5.1 Selection table	10
5.2 Type code	10
6 Technical data	11
6.1 GEHV dimensions	12
6.2 GEH dimensions	13
6.3 LEH dimensions	14
Feedback	15
Contact	15

1 Application

GEHV



The flow adjusting cock GEHV is used for flow rate adjustment in laboratories and test systems, and wherever flow rates have to be frequently readjusted.

GEH 8 to 25



Thanks to flow adjusting cocks GEH 8 to 25, the gas flow rate upstream of gas burners can be adjusted. It can be used up to a maximum inlet pressure of 1 bar.

GEH 32 to 50



Thanks to flow adjusting cocks GEH 32 to 50, the gas flow rate upstream of gas burners can be adjusted up to a maximum inlet pressure of 5 bar.

LEH



Thanks to flow adjusting cock LEH, the air flow rate upstream of gas burners can be adjusted. Optionally, the hand wheel can be replaced with the safety cap shown to protect against unintentional maladjustment.

1.1 Examples of application



GEHV in a laboratory

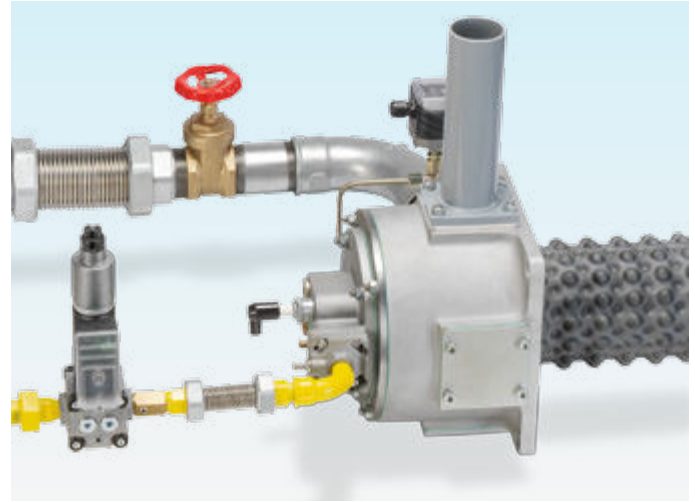

Air adjusting cock LEH in a burner line

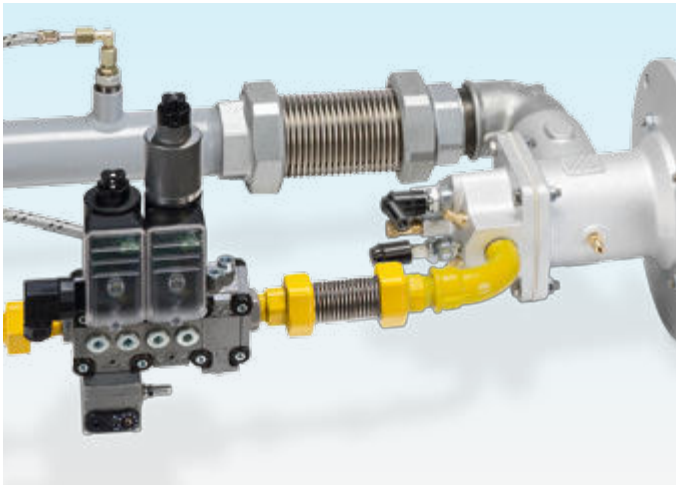

Gas adjusting cock GEH in a burner line

2 Certification

GEHV, GEH: EC type-tested and certified

pursuant to



- Pressure Equipment Directive 97/23/EC
- Declaration of conformity (D, GB) – see www.docuthek.com → Elster Kromschröder → Kromschröder, LBE → Products → 11 Accessories → Flow adjusting cocks GEHV, GEH, LEH → Kind of document: Certificate → GEH 32...50 R50 and GEHV 40...50 (K OS Konformitätserklärung)

Eurasian Customs Union



The product GEHV, GEH, LEH meets the technical specifications of the Eurasian Customs Union.

3 Function

3.1 GEHV, GEH

Flow adjusting cock GEHV is used for adjusting gas and air flow rates.

A pierced ball acts as a shut-off device ensuring full closing within an angle of rotation of 90°.

GEHV

The flow rate can be adjusted using a hand wheel with an adjusting scale and a position indicator. If the hand wheel is turned through 360°, the ball is turned 90°. This reduction of the ball rotation allows for accurate adjustment of the flow rate.

GEH

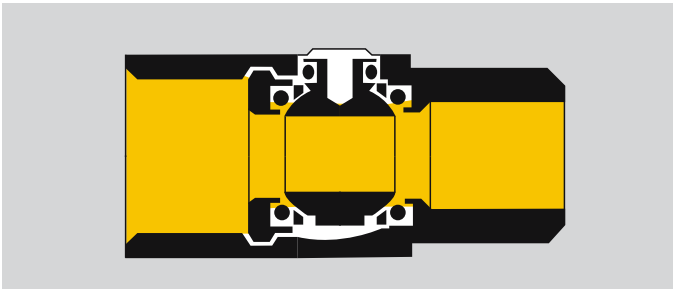

The ball in GEH is turned 90° using an Allen key, screwdriver or spanner.

3.2 LEH

Flow adjusting cock LEH is used for adjusting the air flow rate. Shut-off is provided by a gate stop valve which is exactly positioned using a hand wheel, thereby releasing the required flow volume.

The hand wheel can be replaced with the safety cap enclosed to prevent unintentional rotation.

4 Flow rate

4.1 GEHV

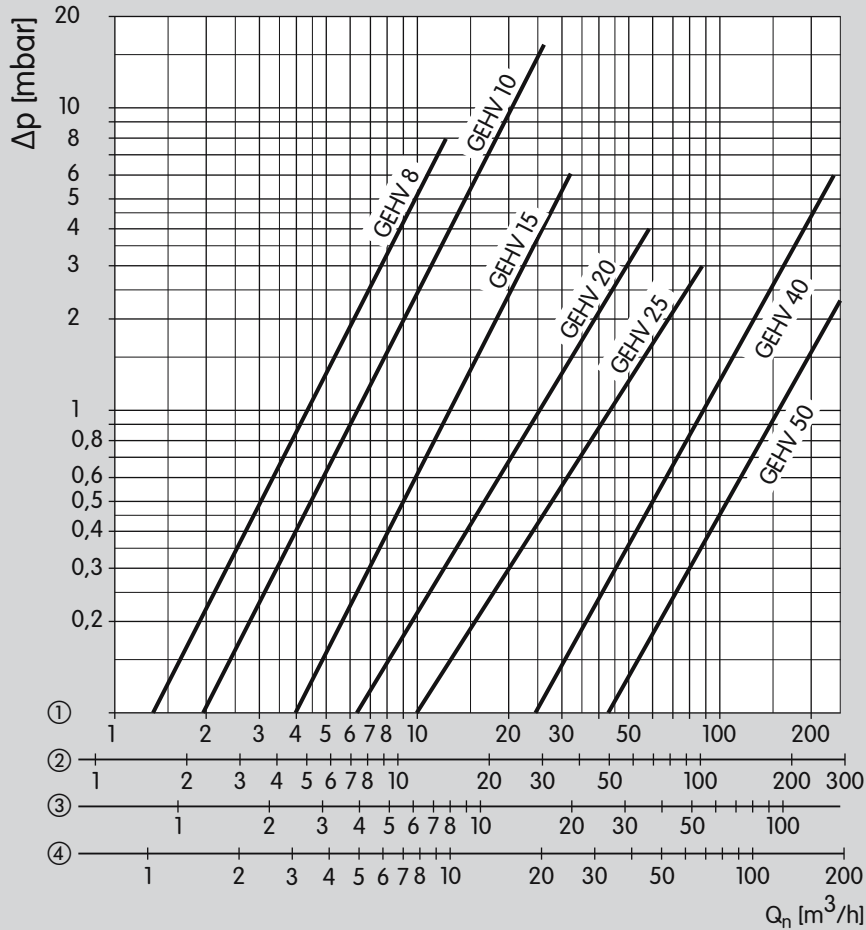

- ① = natural gas ($\rho = 0.80 \text{ kg/m}^3$)
- ② = town gas ($\rho = 0.58 \text{ kg/m}^3$)
- ③ = propane ($\rho = 2.01 \text{ kg/m}^3$)
- ④ = air ($\rho = 1.29 \text{ kg/m}^3$)

4.2 GEH

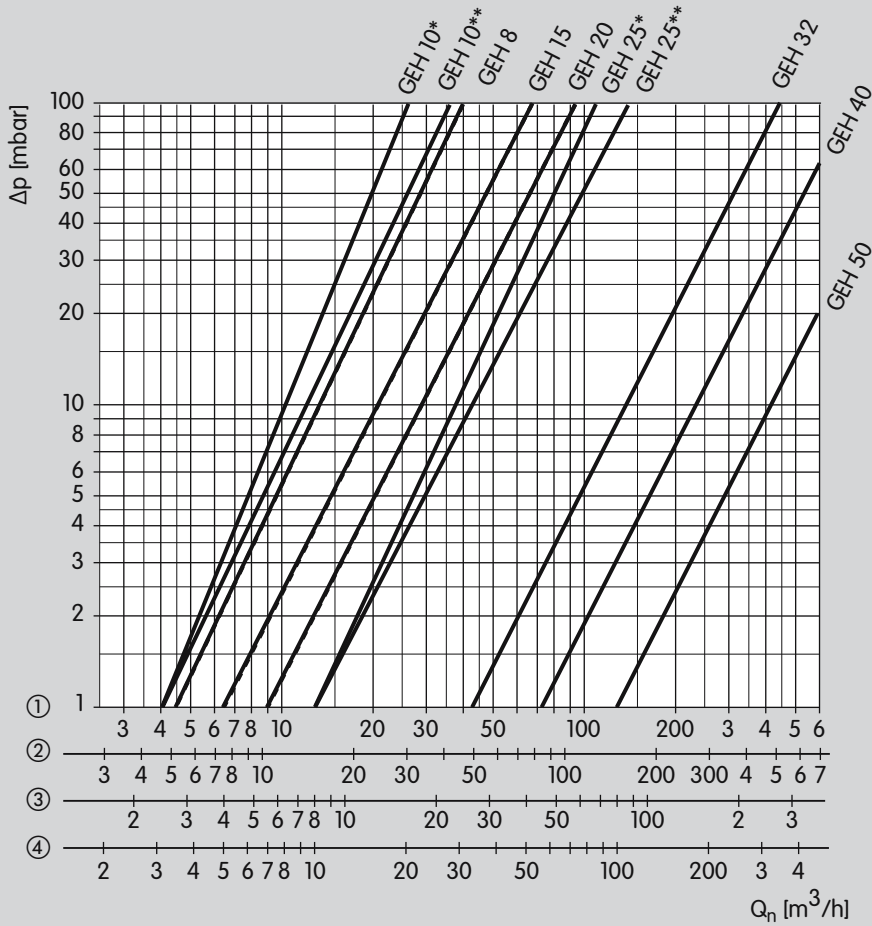

Flow direction

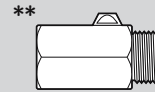
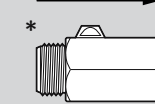

- ① = natural gas ($\rho = 0.80 \text{ kg/m}^3$)
- ② = town gas ($\rho = 0.58 \text{ kg/m}^3$)
- ③ = propane ($\rho = 2.01 \text{ kg/m}^3$)
- ④ = air ($\rho = 1.29 \text{ kg/m}^3$)

4.3 LEH

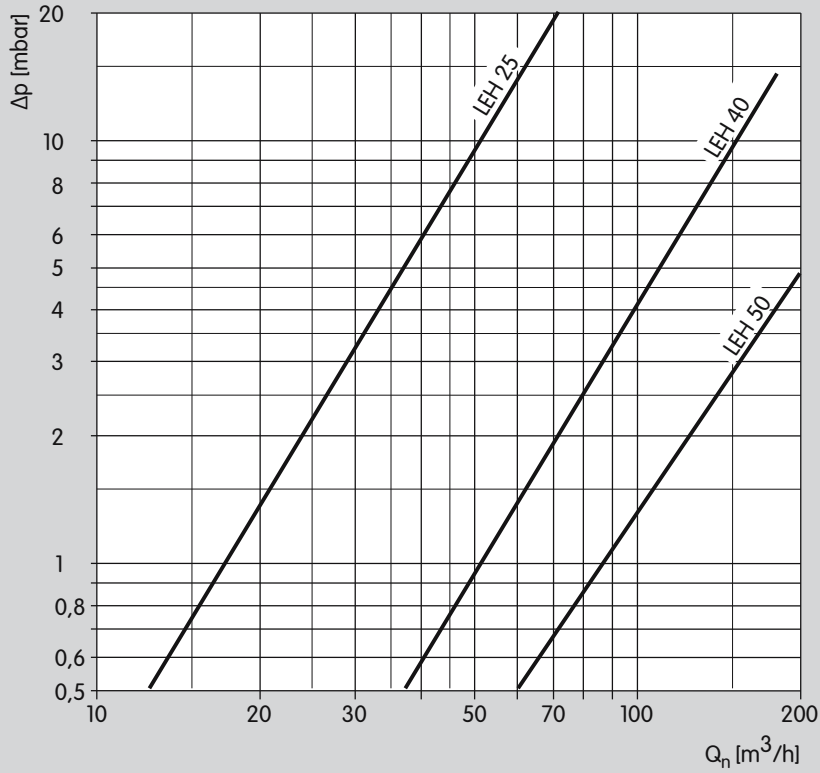

Air ($\rho = 1.29 \text{ kg/m}^3$)

5 Selection

5.1 Selection table

	8	10	15	20	25	32	40	50	R	10	40	50
GEHV*	●	●	●	●	●		●	●				
GEH	●	●	●	●	●				●	●		
GEH						●	●	●	●			●
LEH				●			●	●	●		●	

* GEHV for air: max. inlet pressure $p_{u,max.} = 25 \text{ bar}$

● = standard, ○ = available

Order example

GEH 15R10

5.2 Type code

Code	Description
GEHV	Flow adjusting cock for gas and air
GEH	Flow adjusting cock for gas
LEH	Flow adjusting cock for air
8-50	Nominal size
R	Rp internal thread
10	$p_{u,max}$ 1 bar for gas
40	$p_{u,max}$ 4 bar
50	$p_{u,max}$ 5 bar for gas

6 Technical data

GEHV

Gas type: natural gas, town gas, LPG (gaseous) and air.

Connection: internal thread to DIN 2999.

Inlet pressure p_U :

for gas: max. 5 bar,

for air: max. 25 bar.

Temperature range:

for gas: -20 to +60°C,

for air: -10 to +90°C.

Housing: CW 617 N (2.0402), nickel-plated.

Ball: CW 617 N (2.0402), hard chromium-plated.

Ball seal: PTFE Teflon.

Spindle seal: NBQ.

Hand wheel: PA 6 polyamide.

GEH 8 to 25

Gas type: natural gas, town gas, LPG (gaseous) and air.

Connection: internal/external thread to DIN 2999.

Inlet pressure p_U :

for gas: max. 1 bar,

for air: max. 4 bar.

Temperature range:

for gas: -15 to +60°C,

for air: -15 to +120°C.

Housing: MS 58.

Ball: MS 58.

Ball seal: O-ring, nitrile.

Spindle seal: O-ring, nitrile.

GEH 32 to 50

Gas type: natural gas, town gas, LPG (gaseous) and air.

Connection: internal/external thread to DIN 2999.

Inlet pressure p_U :

for gas: max. 5 bar,

for air: max. 16 bar.

Temperature range:

for gas: -20 to +60°C,

for air: -20 to +120°C.

Housing: MS 58, nickel-plated.

Ball: MS 58, chromium-plated.

Ball seal: PTFE.

Spindle seal: O-rings, Viton.

LEH

Gas type: air.

Connection: internal thread to DIN 2999.

Inlet pressure p_U : max. 4 bar.

Temperature range: 0 to 120°C.

Housing: pressed brass.

Seal: gland.

6.1 GEHV dimensions

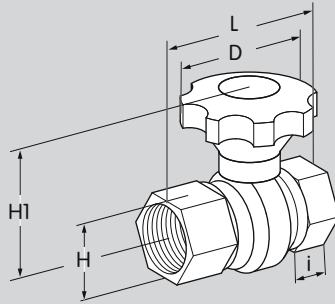

Type	DN	Connection	Dimensions [mm]					Weight [kg]
			L	H1	ø H	ø D	i	
GEHV 8	8	Rp 1/4	45	60	23	70	10	0.172
GEHV 10	10	Rp 3/8	45	60	23	70	10	0.162
GEHV 15	15	Rp 1/2	63	66	31	70	15	0.28
GEHV 20	20	Rp 3/4	71	68	39	70	16	0.37
GEHV 25	25	Rp 1	83	75	47	70	19	0.56
GEHV 40	40	Rp 1 1/2	104	109	69	112	21	1.45
GEHV 50	50	Rp 2	124	115	85	112	26	2.10

6.2 GEH dimensions

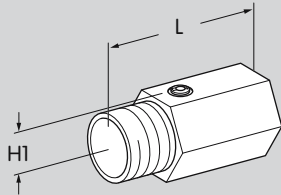

GEH 8 to 25

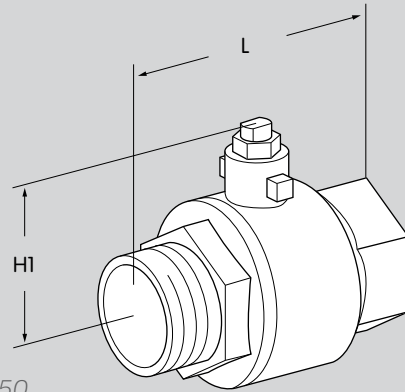

GEH 32 to 50

Type	DN	Connection	Dimensions [mm]		Weight [kg]
			L	H1	
GEH 8R10	8	Rp/R 1/4	48	22	0.07
GEH 10R10	10	Rp/R 3/8	45	22	0.07
GEH 15R10	15	Rp/R 1/2	55	26	0.10
GEH 20R10	20	Rp/R 3/4	63	37	0.20
GEH 25R10	25	Rp/R 1	72	44	0.36
GEH 32R50	32	Rp/R 1 1/4	106	61	0.90
GEH 40R50	40	Rp/R 1 1/2	113	67	1.10
GEH 50R50	50	Rp/R 2	133	75	1.80

6.3 LEH dimensions

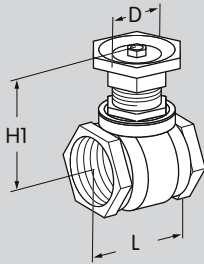

LEH with hand wheel

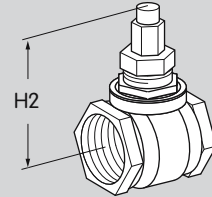

LEH with safety cap

Type	DN	Connection	L	Dimensions [mm]			Weight [kg]
				H1	H2	ø D	
LEH 25R40	25	Rp 1	43	80	90	50	0.30
LEH 40R40	40	Rp 1 1/2	54	107	117	60	0.60
LEH 50R40	50	Rp 2	58	134	144	70	1.00

Feedback

Finally, we are offering you the opportunity to assess this “Technical Information (TI)” and to give us your opinion, so that we can improve our documents further and suit them to your needs.

Clarity

- Found information quickly
- Searched for a long time
- Didn't find information
- What is missing?
- No answer

Use

- To get to know the product
- To choose a product
- Planning
- To look for information

Remarks



Comprehension

- Coherent
- Too complicated
- No answer

Navigation

- I can find my way around
- I got “lost”
- No answer

Scope

- Too little
- Sufficient
- Too wide
- No answer

My scope of functions

- Technical department
- Sales
- No answer



Contact

Elster GmbH
Postfach 2809 · 49018 Osnabrück
Strohweg 1 · 49504 Lotte (Büren)
Germany

Tel +49 541 1214-0
Fax +49 541 1214-370
info@kromschroeder.com
www.kromschroeder.com

The current addresses of our international agents
are available on the Internet:
www.kromschroeder.de/Weltweit.20.0.html?&L=1

We reserve the right to make technical
modifications in the interests of progress.
Copyright © 2016 Elster GmbH
All rights reserved.

