

Honeywell

krom
schroder

Butterfly valves BVG, BVA, BV..F, BVH, BVHR, BVHS, BVHM Butterfly valves with actuator IBG, IBA, IB..F, IBH, IBHR, IBHS

Technical Information · GB
3 Edition 01.17

- For gas, air, hot air and flue gas
- Low leakage rate and pressure loss
- High control accuracy
- BVG, BVGF, BVA, BVAF, IBG, IBGF, IBA or IBAF with reduced nominal diameters
- Butterfly valves available with mounted actuator
- Suitable for intermittent operation
- BVGF, BVAF, IBGF, IBAF work clearance-free
- Low-maintenance operation
- BVHR can be used in temperatures of up to 550°C



EAC CE

Contents

Butterfly valves BVG, BVA, BV..F, BVH, BVHR, BVHS, BVHM	1
Butterfly valves with actuator IBG, IBA, IB..F, IBH, IBHR, IBHS	1
Contents	2
1 Application	4
1.1 BVG, BVA	4
1.2 BVGF, BVAF	4
1.3 BVH, BVHR, BVHS, BVHM	5
1.4 IBG, IBGF, IBA, IBAF, IBH, IBHR, IBHS	6
1.5 BVHM with MB 7	6
1.6 Examples of application	7
1.6.1 IBG, IBGF, lambda correction	7
1.6.2 IBA, IBAF, adjusting the burner capacity	7
1.6.3 IBH, IBHR, hot air compensation	8
1.6.4 IBHS, safety closing function in the event of a mains voltage failure	8
1.6.5 BVHM in intermittent mode	9
2 Certification	10
3 Function	11
3.1 Clearance-free	11
3.2 Safety closing function	11
4 Replacement possibilities for butterfly valves	12
4.1 DKG is to be replaced by BVG	12
4.2 DKL is to be replaced by BVA	13
4.3 K is to be replaced by BVHM	14
5 Flow rate	15
5.1 Flow rate curves for BVG, BVGF, BVA, BVAF	15
5.1.1 With full bore = nominal diameter	15
5.1.2 With 1 × reduced bore	16
5.1.3 With 2 × reduced bore	17
5.1.4 k_V values	18
5.2 Flow rate curves for BVH, BVHR, BVHM, BVHS ..	19

5.2.1 k_V values	20
6 Selection	21
6.1 BVG, BVGF, BVA, BVAF, BVH, BVHR, BVHS, BVHM	21
6.1.1 Type code	22
6.2 IBG, IBGF, IBA, IBAF, IBH, IBHR, IBHS	23
6.2.1 Type code	24
6.3 Determining the nominal size	25
6.3.1 Calculating the nominal size	25
6.3.2 BVG, BVGF, BVA, BVAF	26
6.3.3 BVH, BVHR, BVHS, BVHM	27
7 Project planning information	29
7.1 Installation	29
7.2 Flow velocities in pipes	31
7.3 Actuator selection	32
7.3.1 IC 20, IC 30, IC 40	32
7.3.2 MB 7	34
8 Accessories	35
8.1 Adapter set with square shaft	35
8.2 Adapter set with free shaft end	35
8.3 Adapter set with manual adjustment	35
8.4 For BVG, BVGF, BVA, BVAF, BVH, BVHR, BVHS ..	36
8.5 For BVG, BVA	36
8.6 For BVH, BVHM and BVHS	36
8.7 For BVHM	37
9 Technical data	38
9.1 BVG, BVGF, BVA, BVAF	38
9.2 BVH, BVHR, BVHM, BVHS	38
9.3 Dimensions of IBG/IBA (BVG/BVA + IC 20/IC 40)	39
9.3.1 With full bore	39
9.3.2 With 1 × reduced bore	39
9.3.3 With 2 × reduced bore	39

Contents

9.4 Dimensions of IBGF/IBAF (BVGf/BVAF + IC 20/ IC 40)	40
9.4.1 With full bore	40
9.4.2 With 1 × reduced bore	40
9.4.3 With 2 × reduced bore	40
9.5 Dimensions of BVG/BVA with IC 30	41
9.6 Dimensions of IBH/IBHS (BVH/BVHS + IC 20/ IC 40)	42
9.7 Dimensions of IBHR (BVHR + IC 20/IC 40)	43
9.8 Dimensions of MB 7 + BVHM	44
10 Conversion factors	45
11 Maintenance cycles	45
12 Glossary	46
12.1 Control characteristic, valve authority	46
12.2 Interpolation (linear)	46
12.3 Hot air compensation	46
12.4 Symbols in acc. with DIN EN 334/14382 and DVGW G 491	46
Feedback	47
Contact	47

1 Application

The butterfly valves are designed to adjust volumes of gas, cold and hot air and flue gas on various appliances and flue gas lines. They are designed for control ratios up to 1:10, and with the mounted actuator they are suitable for regulating flow rates for modulating-controlled or stage-controlled combustion processes.

1.1 BVG, BVA

BVG for gas, BVA for air. These butterfly valves BVG..H, BVA..H can also be supplied with manual adjustment.

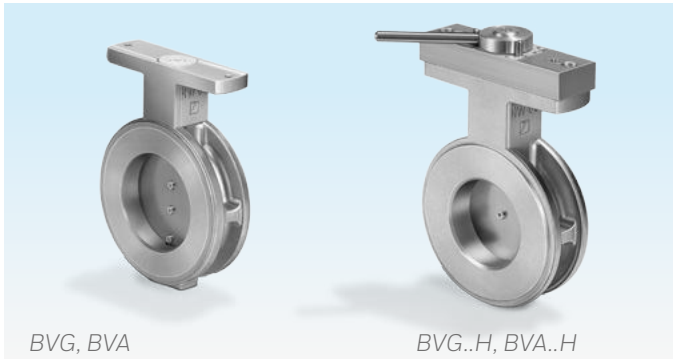

Butterfly valves BVG, BVGF, BVA and BVAF with reduced nominal diameter (reduced by one or two nominal sizes) can be used to achieve higher control accuracy. This will mean that complex reducing fittings will no longer be required.

Various adapter sets with square shaft, free shaft end or lever are available as accessories, see page 35 (Accessories). Flow rates can be set and fixed using a lever, for example to limit the high-fire rate on the burner. A scale indicates the set angle of opening.

1.2 BVGF, BVAF

Butterfly valves BVGF and BVAF work clearance-free. In case of change of direction, the butterfly valve adjusts to the setpoint without delay. The butterfly valve thus reaches the required position more quickly.

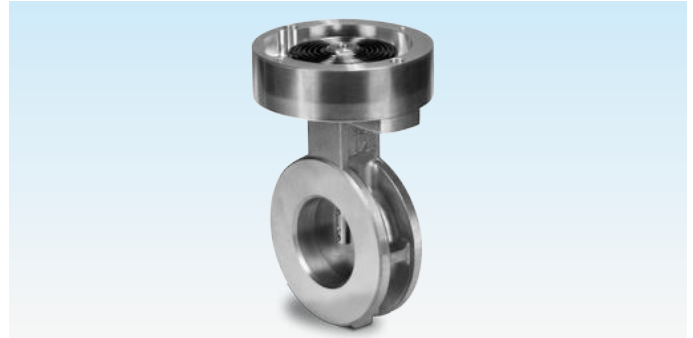

1.3 BVH, BVHR, BVHS, BVHM

Butterfly valve for hot air and flue gas.

The butterfly valve BVH, BVHR, BVHS is used for processes that require the very precise adjustment of the flow rate or low leakage. In conjunction with the stop bar, the valve disc ensures very low leakage rates.

Using a spiral spring which compensates for the play in combination with the actuator IC 40, it is possible to move the valve disc to the required angle with almost zero hysteresis.

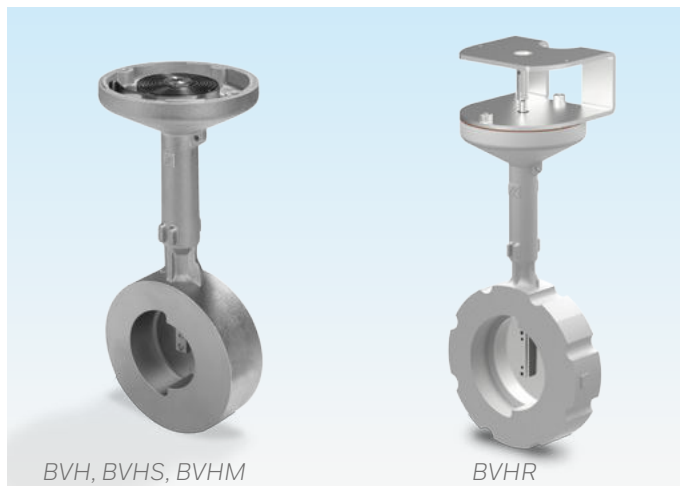

BVHS

The butterfly valve BVHS with safety closing function, see page 11 (Function), is used with the actuator IC 40S in systems where it is important that in the event of a mains voltage failure, the valve closes, preventing air streaming into the furnace without being under control.

In order to maximize the service life of the butterfly valve, the safety closing function should be used only for the scheduled closing function and not for controlled shut-down or for intermittent switching of the burner.

BVH, BVHR

Butterfly valve BVH is suitable for applications up to 450°C. The BVHR can be used at a medium temperature of up to 550°C.

BVHM

Butterfly valve BVHM is used in intermittent mode. Solenoid actuator MB 7 is available as an actuator for the BVHM.

1.4 IBG, IBGF, IBA, IBAF, IBH, IBHR, IBHS

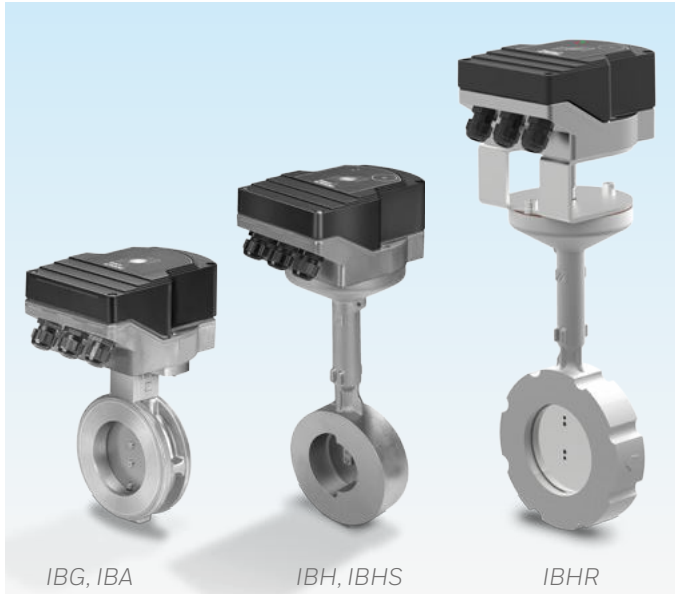

Butterfly valves BVG, BVGF, BVA, BVAF, BVH, BVHR or BVHS and actuator IC 20 or 40 can be delivered ready assembled as butterfly valves with actuator IBG, IBGF, IBA, IBAF, IBH, IBHR or IBHS.

For detailed information on actuators, see www.docuthek.com, Technical Information bulletin Actuators IC 40 and Technical Information bulletin Actuators IC 20, IC 30, IC 50.

1.5 BVHM with MB 7



Solenoid actuator MB 7 and butterfly valve BVHM are used in intermittent mode.

The low- and high-fire rates can be adjusted independently of each other.

For detailed information on solenoid actuator MB 7, see www.docuthek.com, Technical Information bulletin MB 7.

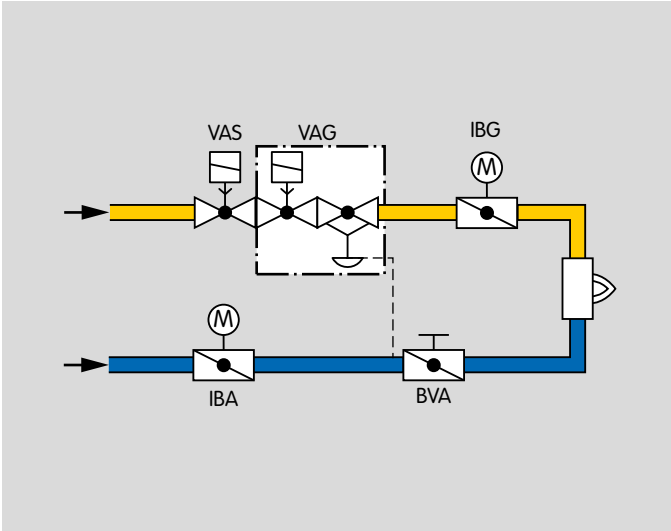

1.6 Examples of application

1.6.1 IBG, IBGF, lambda correction

If the burner is to be operated with excess gas or air for reasons of process operation, the butterfly valve with actuator IBG can be used to correct the lambda value. The butterfly valve BVA with manual adjustment is used to adjust the high-fire rate.

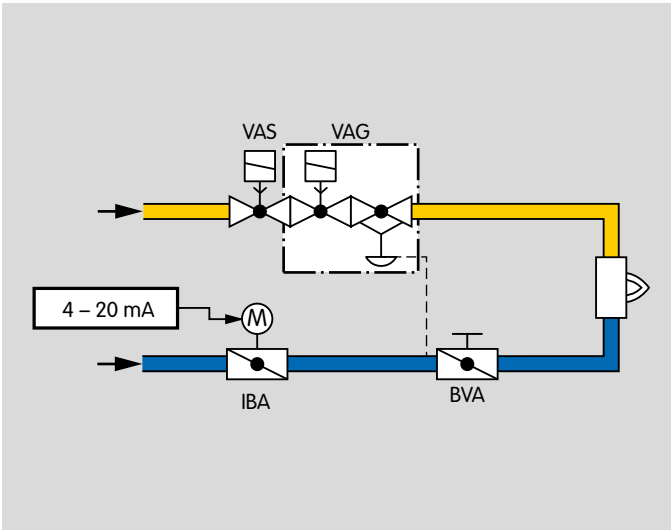

1.6.2 IBA, IBAF, adjusting the burner capacity

In pneumatic ratio control systems, the butterfly valve with mounted actuator IBA determines the air volume for the required burner capacity. The butterfly valve BVA with manual adjustment is used to adjust the high-fire rate.

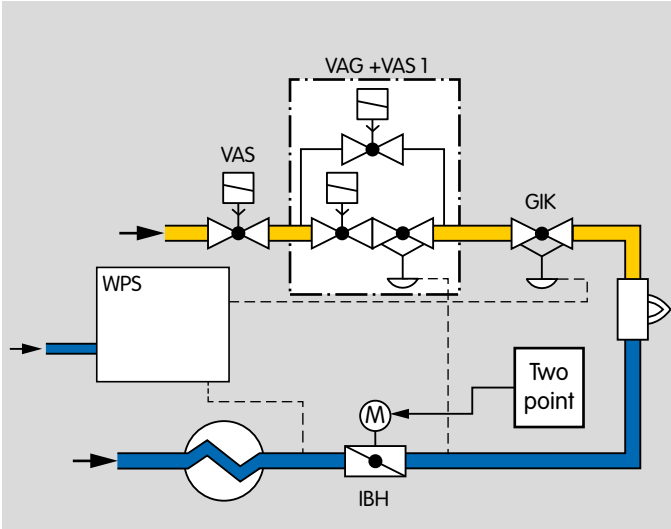

1.6.3 IBH, IBHR, hot air compensation

The butterfly valve with actuator IBH is used on burners that are operated with preheated combustion air at temperatures of up to 450°C (840°F).

Butterfly valve BVHR is available for medium temperatures of up to 550°C (1020°F).

Hot air compensation, see page 46 (Glossary).

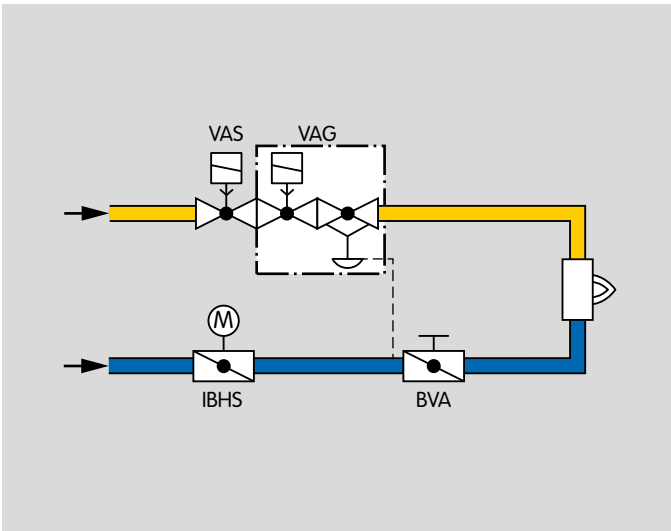

1.6.4 IBHS, safety closing function in the event of a mains voltage failure

The safety closing function ensures that in the event of a mains voltage failure air cannot stream into the furnace without being under control.

The butterfly valve with actuator IBHS is used in the air circuit.

The butterfly valve BVA with manual adjustment is used to adjust the high-fire rate.

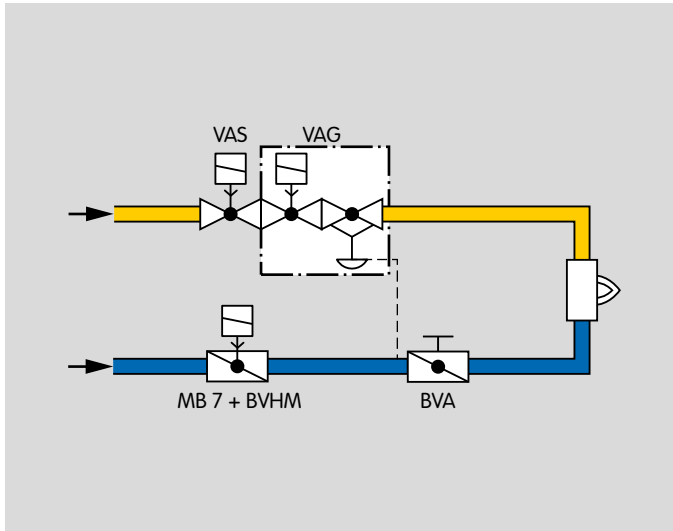

1.6.5 BVHM in intermittent mode

Solenoid actuator MB 7 and butterfly valve BVHM are used for intermittent switching of the burner.

The MB 7 is equipped with a flow rate adjustment device. The low- and high-fire rates are thus adjusted independently of each other.

Depending on the setting, the required leakage rate can be used as the low-fire rate. The BVHM allows an important reduction in the oxygen level of the furnace atmosphere in oxygen-critical applications such as on forging furnaces. This allows suppression of undesirable scale formation on the material to be treated.

2 Certification

Certificates – see Docuthek

EU certified

BVG, BVGF, BVA, BVAF



- Gas Appliances Directive (2009/142/EC) in conjunction with EN 161

Eurasian Customs Union



The product BVG/BVGF/BVA/BVAF/BVH/BVHR/BVHS/BVHM meets the technical specifications of the Eurasian Customs Union.

3 Function

The butterfly valves are designed on the basis of the free-flow principle (no deflection of the flow). They release a cross-section for the flowing medium, depending on a rotary movement between 0 and 90°.

The valve disc of the butterfly valves BVH, BVHR, BVHS, BVHM features a sheet metal spring (TWINDISC®) and, together with the mechanical stop bar, ensures very low leakage.

BVG, BVGF, BVA, BVAF, BVH, BVHR and BVHS are specifically designed to fit the actuators IC. The butterfly valves feature very easy action. Consequently, the actuator requires only a low torque.

BVHM is tailored to the solenoid actuator MB 7.

3.1 Clearance-free

BVGF, BVAF

The spiral spring always pushes the valve disc in the direction of closing. Any clearance between the actuator and the valve disc is eliminated and the control command is executed without delay.

3.2 Safety closing function

BVHM, BVHS

The butterfly valves BVHM, BVHS feature a safety closing function. They are used in systems where it is important that in the event of a mains voltage failure, the valve closes, preventing air streaming into the furnace without being under control.

A pre-tensioned spiral spring moves the valve disc against the mechanical stop of the butterfly valve in the event of a solenoid valve/motor defect, within the closing time.

The safety closing function of butterfly valve BVHS is possible only in conjunction with the actuator IC 40S.

4 Replacement possibilities for butterfly valves

4.1 DKG is to be replaced by BVG

Type			Type
DKG	Butterfly valve	Butterfly valve	BVG
25	DN 25		–
32	DN 32		–
40	DN 40	DN 40	40
50	DN 50	DN 50	50
65	DN 65	DN 65	65
80	DN 80	DN 80	80
100	DN 100	DN 100	100
125	DN 125	DN 125	125
150	DN 150	DN 150	150
/15-/125	Reduced to nominal size DN	Reduced to nominal size DN	/25-/125
T	T-product	–	–
Z	For fitting between two DIN flanges	For fitting between two flanges to EN 1092	Z
W	For fitting between two ANSI flanges	For fitting between two ANSI flanges	W*
03	p_u max. 300 mbar (4.35 psi)	p_u max. 500 mbar (7.25 psi)	05
H	With manual adjustment	Adapter set with manual adjustment	H
V	With square shaft	Adapter set with square shaft	V
F	With free shaft end	Adapter set with free shaft end	F
60	Temperature range: 60°C (140°F)	Temperature range: 60°C (140°F)	●
D	With disc clearance	With disc clearance	●
DKG 80Z03H60D	Example	Example	BVG 80Z05H

* DN 40 to DN 100 only

● standard, ○ available

4.2 DKL is to be replaced by BVA

Type			Type
DKL	Butterfly valve	Butterfly valve	BVA
25	DN 25		–
32	DN 32		–
40	DN 40	DN 40	40
50	DN 50	DN 50	50
65	DN 65	DN 65	65
80	DN 80	DN 80	80
100	DN 100	DN 100	100
125	DN 125	DN 125	125
150	DN 150	DN 150	150
/15-/125	Reduced to nominal size DN	Reduced to nominal size DN	/25-/125
T	T-product	–	–
Z	For fitting between two DIN flanges	For fitting between two flanges to EN 1092	Z
W	For fitting between two ANSI flanges	–	–
03	p_u max. 300 mbar (4.35 psi)	p_u max. 500 mbar (7.25 psi)	05
H	With manual adjustment	Adapter set with manual adjustment	H
V	With square shaft	Adapter set with square shaft	V
F	With free shaft end	Adapter set with free shaft end	F
100	Temperature range: 100°C (210°F)	Temperature range: 60°C (140°F)	●
D	With disc clearance	With disc clearance	●

DKL 40Z03F100D

Example

Example

BVA 40Z05F

● standard, ○ available

4.3 K is to be replaced by BVHM

Type			Type
K	Valve	Butterfly valve for solenoid actuator MB 7	BVHM
40*	DN 40	DN 40	40
50	DN 50	DN 50	50
65	DN 65	DN 65	65
80	DN 80	DN 80	80
100	DN 100	DN 100	100
T	T-product	-	
Z	For fitting between two DIN flanges	For fitting between two flanges to EN 1092	Z
W	For fitting between two ANSI flanges	For fitting between two ANSI flanges	W
●	p_u max. 130 mbar (1.89 psig)	p_u max. 150 mbar (2.18 psig)	01
●	Temperature range: 0 – 550°C (0 – 1020°F)	Temperature range: 0 – 450°C (0 – 840°F)	●
A	With stop	With stop	A

K 80ZA

Example

Example

BVHM 80Z01A

* Nominal size DN 40 only with disc clearance

● standard, ○ available

5 Flow rate

5.1 Flow rate curves for BVG, BVGF, BVA, BVAF

5.1.1 With full bore = nominal diameter

See page 25 (Calculating the nominal size)

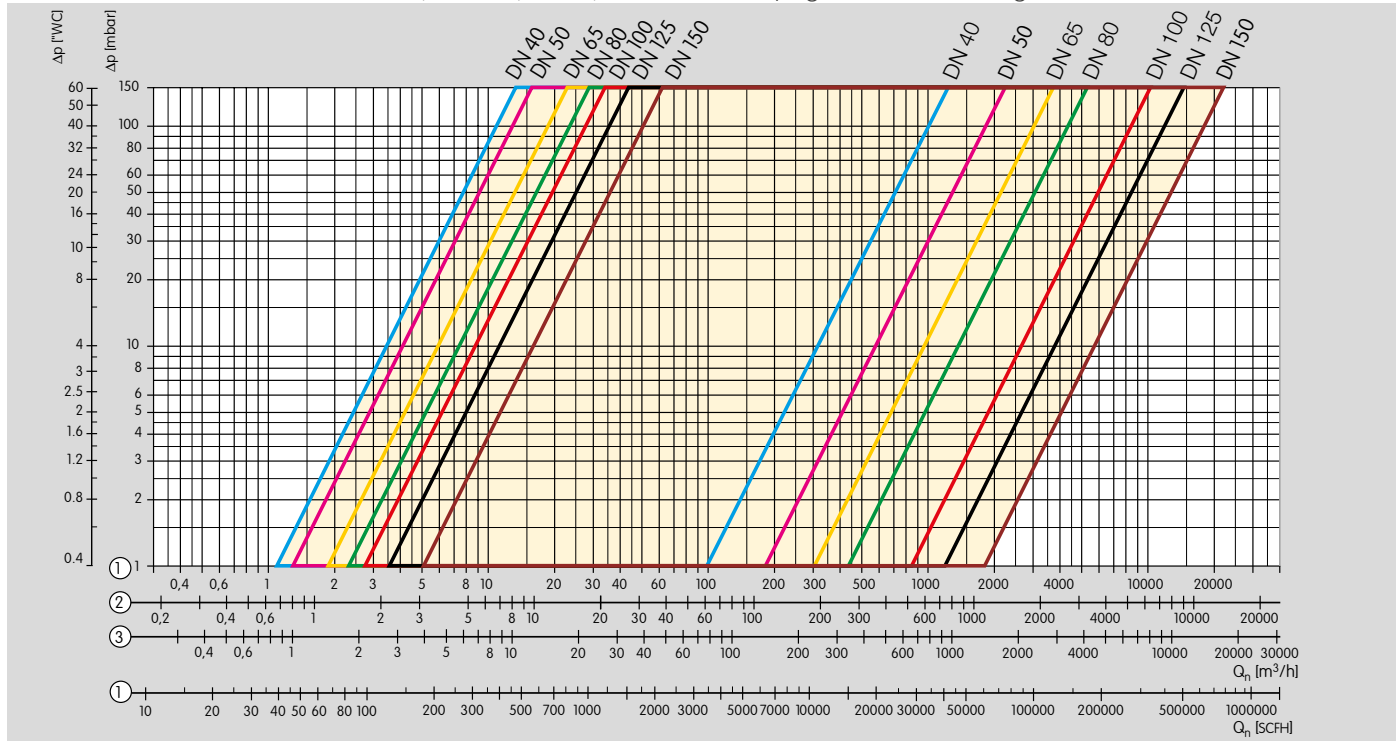

- ① = natural gas, $dv = 0.62$, ② = LPG, $dv = 1.56$,
 ③ = air, $dv = 1.00$

The characteristic curves are measured at $15^\circ C$ ($59^\circ F$) with a measurement set-up in accordance with the standard EN 13611/EN 161.

This involves measuring the pressure $5 \times DN$ upstream and downstream of the unit under test. The pressure drop of the pipe is also measured but is not compensated for.

Left curve: leakage volume at a 0° opening angle.
 Right curve: max. flow rate at a 90° opening angle.

5.1.2 With 1 × reduced bore

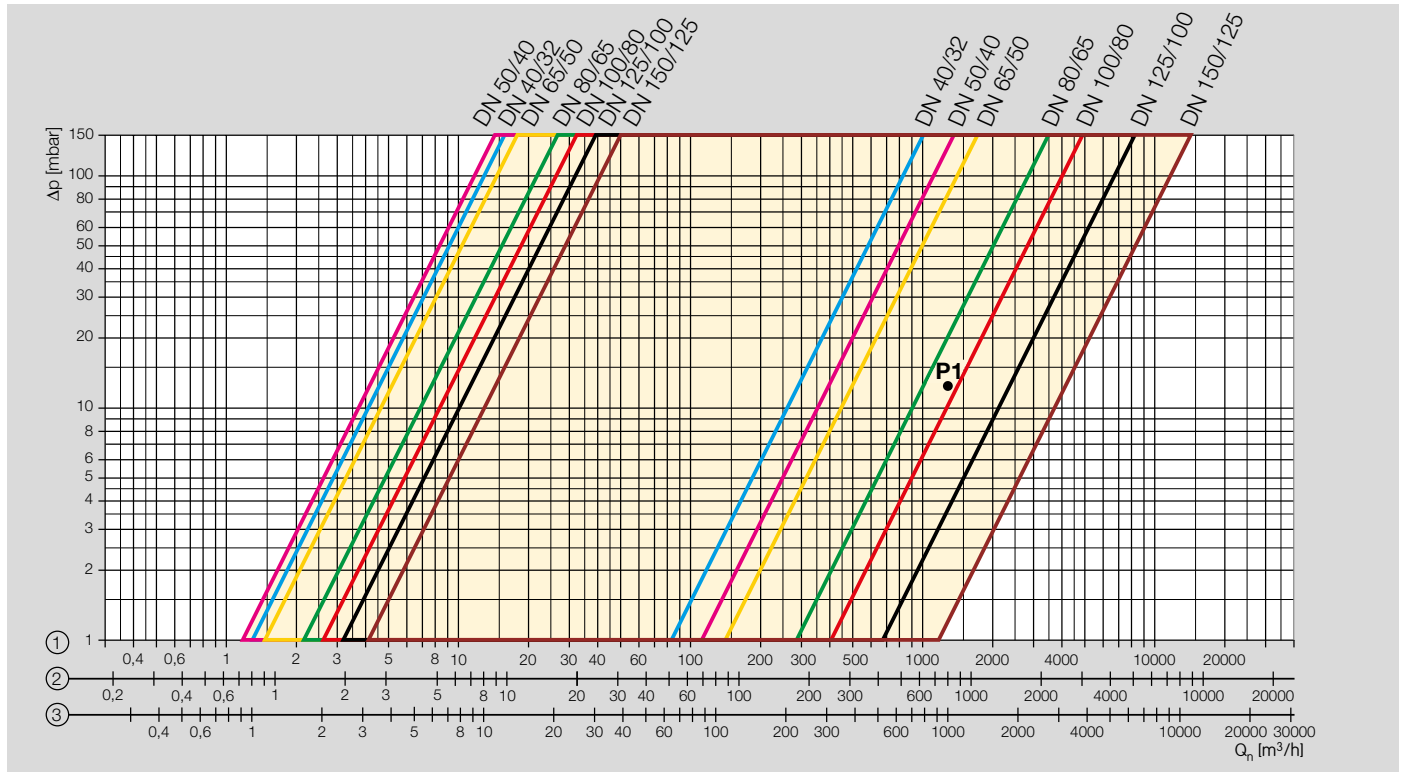

① = natural gas, $dv = 0.62$

② = LPG, $dv = 1.56$,

③ = air, $dv = 1.00$

The characteristic curves are measured at 15°C (59°F) with a measurement set-up in accordance with the standard EN 13611/EN 161.

This involves measuring the pressure 5 × DN upstream and downstream of the unit under test. The pressure drop of the pipe is also measured but is not compensated for.

Left curve: leakage volume at a 0° opening angle.

Right curve: max. flow rate at a 90° opening angle.

See page 25 (Calculating the nominal size)

5.1.3 With 2 × reduced bore

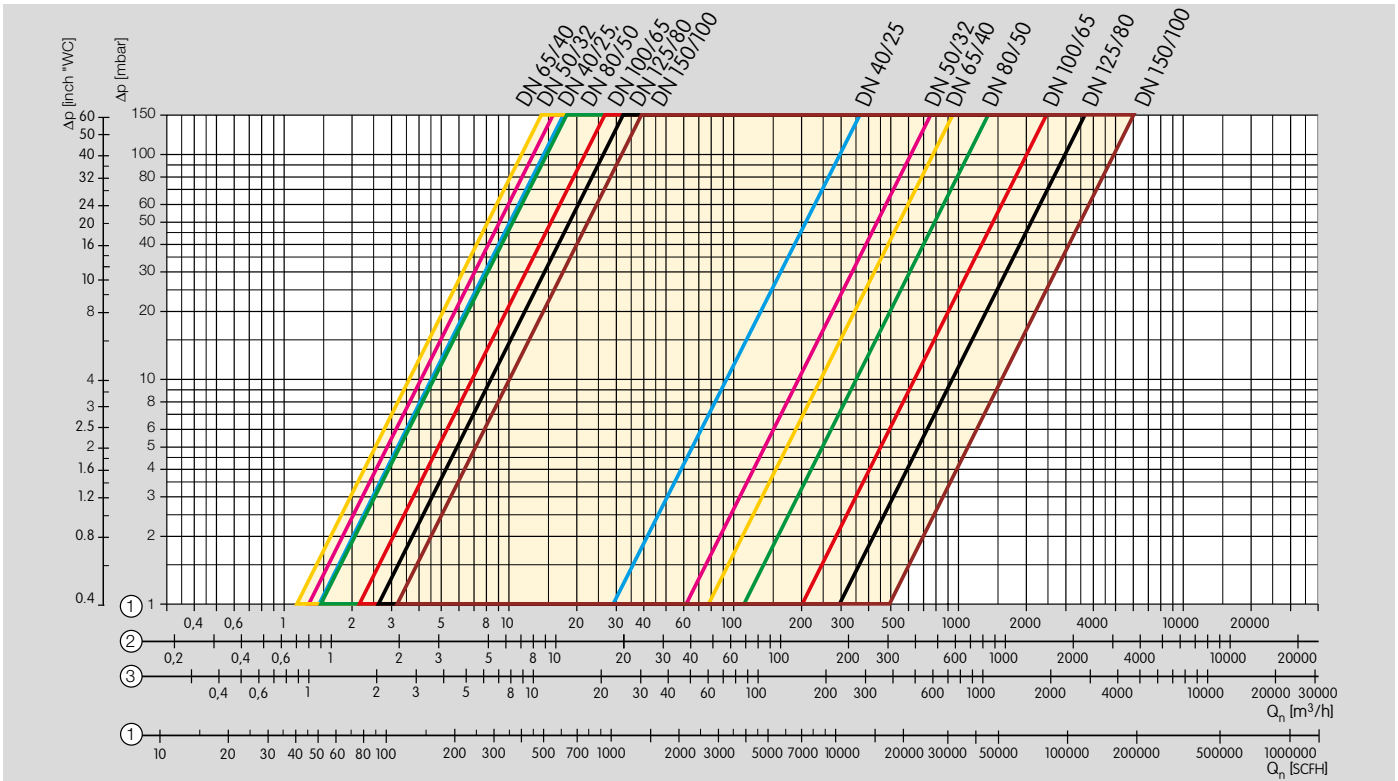

① = natural gas, $dv = 0.62$,

② = LPG, $dv = 1.56$,

③ = air, $dv = 1.00$

The characteristic curves are measured at 15°C (59°F) with a measurement set-up in accordance with the standard EN 13611/EN 161.

This involves measuring the pressure 5 × DN upstream and downstream of the unit under test. The pressure drop of the pipe is also measured but is not compensated for.

Left curve: leakage volume at a 0° opening angle.

Right curve: max. flow rate at a 90° opening angle.

See page 25 (Calculating the nominal size)

5.1.4 k_V values

With full bore = nominal diameter

	Opening angle									
	0	10°	20°	30°	40°	50°	60°	70°	80°	90°
BVG/BVGF/BVA/BVAF 40	1.0	1.5	3.6	7.3	13	23	37	56	77	90
BVG/BVGF/BVA/BVAF 50	1.2	1.6	4.0	9.3	17	31	51	82	123	167
BVG/BVGF/BVA/BVAF 65	1.7	2.7	7.3	16	32	57	94	144	210	281
BVG/BVGF/BVA/BVAF 80	2.1	3.2	9.8	24	47	83	132	202	296	405
BVG/BVGF/BVA/BVAF 100	2.5	3.4	12	33	59	133	214	331	517	792
BVG/BVGF/BVA/BVAF 125	3.4	7.4	25	78	145	244	385	583	910	1132
BVG/BVGF/BVA/BVAF 150	4.7	13	58	132	229	369	583	882	1557	1696

With 1 × reduced bore

BVG/BVGF/BVA/BVAF 40/32	1.2	1.4	2.8	5.4	9.5	16	27	41	57	63
BVG/BVGF/BVA/BVAF 50/40	1.1	1.5	3.2	7.1	13	21	34	52	73	90
BVG/BVGF/BVA/BVAF 65/50	1.3	1.6	4.3	9.5	17	29	46	68	97	120
BVG/BVGF/BVA/BVAF 80/65	2.0	2.4	7.0	16	31	55	89	132	185	243
BVG/BVGF/BVA/BVAF 100/80	2.4	3.3	9.8	23	49	88	140	203	275	335
BVG/BVGF/BVA/BVAF 125/100	2.9	5.2	17	48	103	173	262	364	478	561
BVG/BVGF/BVA/BVAF 150/125	3.8	6.6	25	89	180	288	422	586	771	940

With 2 × reduced bore

BVG/BVGF/BVA/BVAF 40/25	1.3	1.3	2.2	3.9	6.6	11	16	20	24	27
BVG/BVGF/BVA/BVAF 50/32	1.2	1.4	2.8	5.4	9.6	16	26	38	50	56
BVG/BVGF/BVA/BVAF 65/40	1.1	1.5	3.3	7.1	13	20	32	46	61	71
BVG/BVGF/BVA/BVAF 80/50	1.3	1.6	4.0	9.0	16	28	44	64	85	101
BVG/BVGF/BVA/BVAF 100/65	2.0	2.9	7.7	17	32	55	86	122	162	185
BVG/BVGF/BVA/BVAF 125/80	2.4	3.4	8.7	22	47	85	133	185	237	273
BVG/BVGF/BVA/BVAF 150/100	2.9	4.2	15	42	95	160	237	319	397	458

5.2 Flow rate curves for BVH, BVHR, BVHM, BVHS

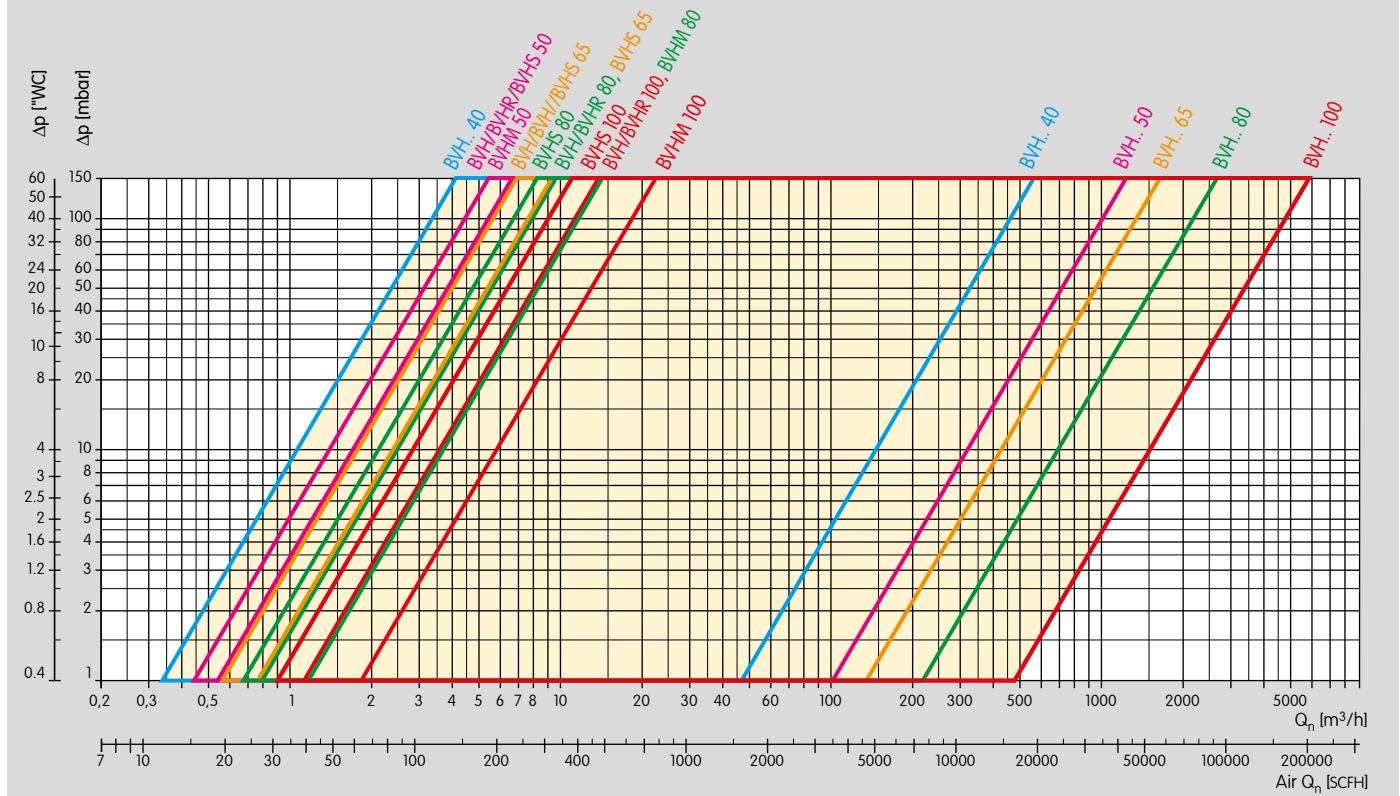

For air, $\nu = 1.00$

The characteristic curves are measured at 15°C (59°F) with a measurement set-up in accordance with the standard EN 13611/EN 161.

The pressure is measured 5 × DN upstream and downstream

of the unit under test. The pressure drop of the pipe is also measured but is not compensated for.

Left curve: leakage volume at a 0° opening angle.

Right curve: max. flow rate at a 90° opening angle.

See page 25 (Calculating the nominal size)

5.2.1 k_V values

	Opening angle									
	0°	10°	20°	30°	40°	50°	60°	70°	80°	90°
BVH/BVHR/BVHS 40	0.4	6.4	12	18	24	31	38	47	53	55
BVH/BVHR/BVHS 50	0.5	10	19	29	40	56	73	95	116	120
BVH/BVHR/BVHS 65	0.7	12	21	32	48	67	92	128	156	160
BVH/BVHR/BVHS 80	0.8	20	34	52	73	103	143	192	238	250
BVH/BVHR/BVHS 100	1.1	27	47	74	111	170	255	374	525	560

BVHM 40	0.4	6.4	12	18	24	31	38	47	53	55
BVHM 50	0.5	10	19	29	40	56	73	95	116	120
BVHM 65	0.7	12	21	32	48	67	92	128	156	160
BVHM 80	1.1	20	34	52	73	103	143	192	238	250
BVHM 100	2.1	27	47	74	111	170	255	374	525	560

6 Selection

6.1 BVG, BVGF, BVA, BVAF, BVH, BVHR, BVHS, BVHM

	40	50	65	80	100	125	150	/25 - /125	Z	W	01	05	A	H	F	V
BVG, BVGF	●	●	●	●	●	●	●	●	●	●		●		○	○	○
BVA, BVAF	●	●	●	●	●	●	●	●	●	●		●		○	○	○
BVH, BVHR, BVHS, BVHM	●	●	●	●	●				●	●	●		●			

* DN 40 to DN 100 only

● = standard, ○ = available

Example

BVA 50Z05V

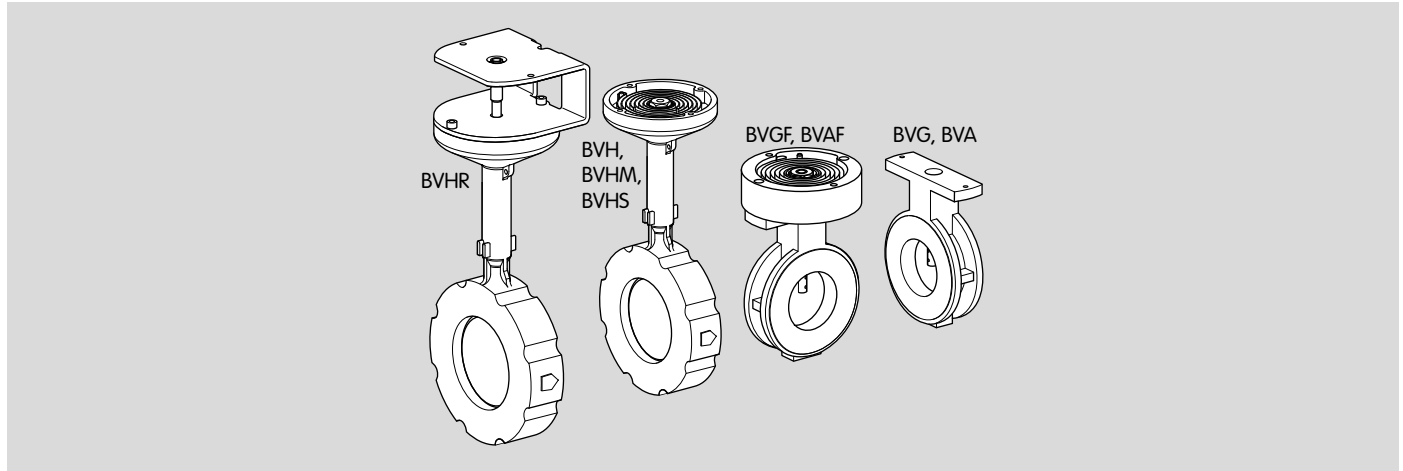

6.1.1 Type code

Code	Description
BVG	Butterfly valve for gas
BVGF	Clearance-free butterfly valve for gas
BVA	Butterfly valve for air
BVAF	Clearance-free butterfly valve for air
BVH	Butterfly valve for hot air and flue gas up to 450°C
BVHR	Butterfly valve for hot air and flue gas up to 550°C
BVHS	Butterfly valve for hot air and flue gas up to 450°C with safety closing function (only in conjunction with actuator IC 40S)
BVHM	Butterfly valve for hot air and flue gas up to 450°C (only in conjunction with solenoid actuator MB 7)
DN 40 – 150	Nominal size DN
DN /25 – 125	Reduced to nominal size DN
Z	For fitting between two flanges to EN 1092
W	For fitting between two ANSI flanges
01	Max. inlet pressure $p_{U \max.}$:
05	150 mbar (2.18 psig)
	500 mbar (7.25 psig)
A	With stop bar
H	With manual adjustment
F	With free shaft end
V	With square shaft

6.2 IBG, IBGF, IBA, IBAF, IBH, IBHR, IBHS

	40	50	65	80	100	125	150/15-	/125	Z	W ⁶⁾	01	05	A	/20	/40	-07 ¹⁾	-15 ¹⁾	-30 ¹⁾	-60 ¹⁾	W	Q	A	2 ²⁾	3 ²⁾	E ³⁾	T ³⁾	A ⁴⁾	D ⁴⁾	R10 ⁵⁾
IBG	●	●	●	●	●	●	●	●	●	●	●	●	●	●	●	●	●	●	●	●	●	●	●	●	○	●	○	●	○
IBGF	●	●	●	●	●	●	●	●	●	●	●	●	●	●	●	●	●	●	●	●	●	●	●	●	○	●	○	●	○
IBA	●	●	●	●	●	●	●	●	●	●	●	●	●	●	●	●	●	●	●	●	●	●	●	●	○	●	○	●	○
IBAF	●	●	●	●	●	●	●	●	●	●	●	●	●	●	●	●	●	●	●	●	●	●	●	●	○	●	○	●	○
IBH, IBHR	●	●	●	●	●	●	●	●	●	●	●	●	●	●	●	●	●	●	●	●	●	●	●	●	○	●	○	●	○
IBHS	●	●	●	●	●	●	●	●	●	●	●	●	●	●	●	●	●	●	●	●	●	●	●	○	●	○	●	○	

1) Only in conjunction with IC 20 (IC 40: programmable between 4.5 and 76.5 s).

2) IC 20-07: 2.5 Nm, IC 20-15/-30/-60: 3.0 Nm, IC 40: 2.5 Nm, IC 40..S: 3 Nm.

3) Only in conjunction with IC 20.

4) Only in conjunction with IC 40.

5) Can be retrofitted on IC 20. If "none", this specification is omitted.

6) DN 40 to DN 100 only

● = standard, ○ = available

Example

IBA 50Z05/20-15W3T

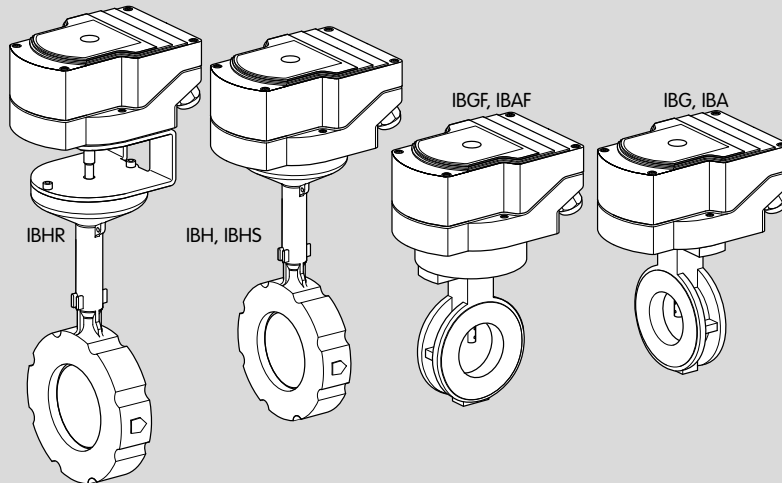

6.2.1 Type code

Code	Description
IBG	Butterfly valve for gas with actuator
IBGF	Clearance-free butterfly valve for gas with actuator
IBA	Butterfly valve for air with actuator
IBAF	Clearance-free butterfly valve for air with actuator
IBH	Butterfly valve for hot air and flue gas up to 450°C with actuator
IBHR	Butterfly valve for hot air and flue gas up to 550°C with actuator
IBHS	Butterfly valve for hot air and flue gas up to 450°C with safety closing function in conjunction with actuator IC 40S
40 - 150	Nominal size DN
/25 - 125	Reduced to nominal size DN
Z	For fitting between two flanges to EN 1092
W	For fitting between two ANSI flanges
01	Max. inlet pressure $p_{U \max.}$:
05	150 mbar (2.18 psig)
	500 mbar (7.25 psig)
A	With stop bar
/20	Actuator IC 20
/40	Actuator IC 40
	Running time (at 50 Hz):
-07	7.5 s
-15	15 s
-30	30 s
-60	60 s
	Mains voltage:
W	230 V AC, -15/+10%, 50/60 Hz
Q	120 V AC, -15/+10%, 50/60 Hz
A	120 - 230 V AC, ±10%, 50/60 Hz
	Torque:
2	2.5 Nm
3	3 Nm
E	Continuous control
T	Three-point step control
A	4 - 20 mA analogue input and digital inputs
D	Digital inputs
R10	0 - 1000 feedback potentiometer

6.3 Determining the nominal size

6.3.1 Calculating the nominal size

metric imperial
 BVG/BVGF BVA/BVAF
 BVH/BVHR/BVHS BVHM

Air kg/m³
 Flow rate Q (standard) m³/h
 Outlet pressure p_d mbar
 Δp_{min.} mbar
 Δp_{max.} mbar
 Medium temperature °C
 Flow rate Q (operation) m³/h

Product	Δp [mbar]	Q _{min.} [m ³ /h]	a	∠ [°]	v [m/s]
BVG/BVGF 65	16,2	10,1	0,35	75	67
BVG/BVGF 80	7,8	11,3	0,21	67	49
BVG/BVGF 80/65	21,6	12,5	0,42	79	49
BVG/BVGF 100/80	11,4	13,5	0,28	66	29
BVG/BVGF 100/65	37,3	14,3	0,55	87	29
BVG/BVGF 125/80	17,1	14,4	0,36	69	19
BVG/BVGF 150/100	6,1	15,2	0,17	52	13

Δp = pressure drop when valve fully opened (90°)

Q_{min.} = leakage rate when valve closed (Δp_{0°} = p_U)

a = valve authority (recommended value: 0.3)

∠ = opening angle at entered Δp_{max.}

v = flow velocity

6.3.2 BVG, BVGF, BVA, BVAF

Δp on the butterfly valve is determined using the control characteristic a , see page 46 (Glossary), and the outlet pressure p_d for normal operation.

$$a = \Delta p_{100\%} / \text{inlet pressure } p_u$$

A control characteristic of $a = 0.3$ provides good control properties.

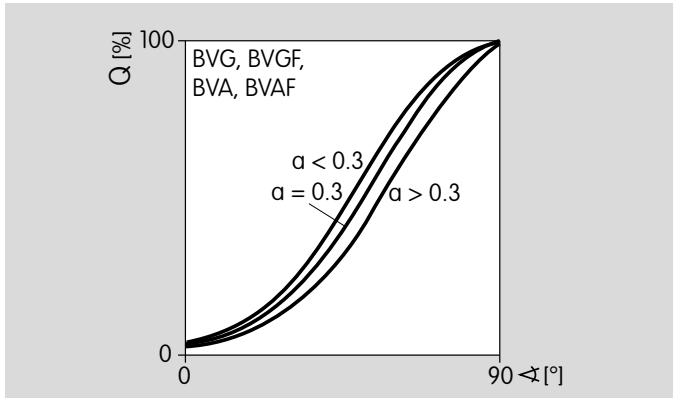

Example

We want to find $\Delta p_{100\%}$ in order to select the nominal size DN of the butterfly valve BVA for air to be used for modulating control of a gas burner:

Outlet pressure: $p_d = 30 \text{ mbar}$

Air flow rate at standard conditions: $Q_n = 1000 \text{ m}^3/\text{h}$

Control characteristic: $a = 0.3$

$$\Delta p_{100\%} = \frac{a \times p_d}{1 - a}$$

$$\Delta p_{100\%} = \frac{0.3 \times 30 \text{ mbar}}{1 - 0.3} = 12.9 \text{ mbar} = 13 \text{ mbar}$$

The flow velocity in the pipes exercises a considerable influence on the pressure loss and the noise development. When designing the butterfly valve, it is recommended that the flow velocity of 30 m/s is not exceeded, see page 31 (Flow velocities in pipes).

A flow rate at standard conditions $Q_n = 1000 \text{ m}^3/\text{h}$ results in a pipe of DN 100.

Select the required nominal size from the flow rate diagram on the basis of the desired flow rate Q_n and the calculated $\Delta p_{100\%}$.

Result

A butterfly valve with 1 × reduced bore is selected in order to obtain the pressure loss $\Delta p_{100\%} = 13 \text{ mbar}$ that has been calculated taking into account the selected nominal size DN = 100.

DN → BVA 100/80 – see **P1**, Flow rate, Flow rate curves for BVG, BVGF, BVA, BVAF on page 16 (With 1 × reduced bore).

6.3.3 BVH, BVHR, BVHS, BVHM

We want to find a butterfly valve BVH for staged control of a gas burner. In order to regulate accurately between loads, the opening angle for high-fire and low-fire rates is calculated using the k_V value.

Selecting the high-fire opening angle

Firstly, Δp_{HF} is determined using the control characteristic a , see page 46 (Glossary), and the outlet pressure $p_{d HF}$.

$$a = \Delta p_{100\%} / \text{inlet pressure } p_u$$

A control characteristic of $a = 0.3$ provides good control properties.

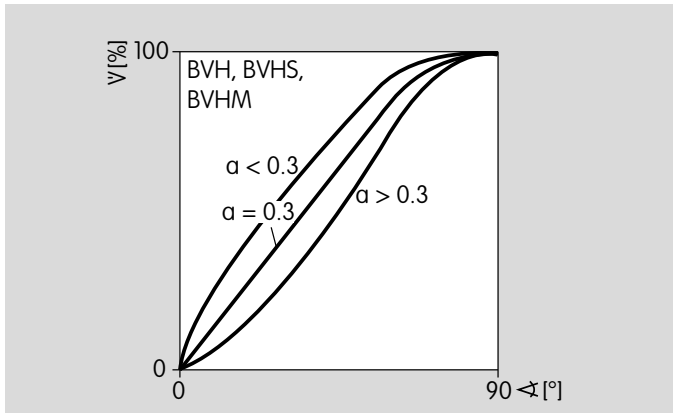

Example

Outlet pressure for high fire: $p_{d HF} = 30 \text{ mbar}$

Outlet pressure $p_{d HF \text{ absolute}}: 1.013 + 30 = 1.043 \text{ bar}$

High-fire flow rate at standard conditions: $Q_{n HF} = 430$

m^3/h

Density ρ_n for air: $1.29 \text{ kg}/\text{m}^3$

Air temperature: 35°C (95°F)

Control characteristic: $a = 0.3$

$$\Delta p_{HF} = \frac{a \times p_{d HF}}{1 - a}$$

$$\Delta p_{HF} = \frac{0.3 \times 30 \text{ mbar}}{1 - 0.3} = 13 \text{ mbar} = 0.013 \text{ bar}$$

$$k_V = \frac{Q_n}{514} \cdot \sqrt{\rho_n \cdot T / (\Delta p_{HF} \cdot p_{d HF \text{ absolute}})}$$

$$Q_n = \frac{k_V \cdot 514}{\sqrt{\rho_n \cdot T / (\Delta p_{HF} \cdot p_{d HF \text{ absolute}})}}$$

$$T_{\text{absolute}} = 35 + 273 \text{ K} = 308 \text{ K}$$

$$k_V = \frac{430}{514} \cdot \sqrt{\frac{1.293 \cdot 308}{0.013 \cdot 1.043}}$$

$$k_V = 144$$

Select the next largest k_V value in the k_V values table for the BVH, BVHS design, allowing for the maximum opening angle. An opening angle greater than 60° should be selected in order to achieve a wider control range.



Selection

For example, the selected k_V value for the butterfly valve BVH, DN 65 with 80° opening is → $k_V = 156$ – see Flow rate, Flow rate curves for BVH, BVHR, BVHM, BVHS on page 20 (k_V values).

The ranges between the opening angles, which are listed in the k_V values table in 10° steps, can be considered as linear. After linear interpolation of the k_V values between 70° and 80°, the selected opening angle of the butterfly valve BVH for high fire is: $k_V = 145$ → approx. 76°.

Then check the flow velocity: max. 30 m/s.

Selecting the low-fire opening angle

In a control range of 1:10, this results in a low-fire flow rate at standard conditions of $Q_{n\text{LF}} = 43 \text{ m}^3/\text{h}/10 = 4.3 \text{ m}^3/\text{h}$ and an outlet pressure of $p_{d\text{LF}} = 30 \text{ mbar}/10^2 = 0.3 \text{ mbar}$.

The inlet pressure p_u is the same for low-fire and high-fire rates.

$p_u = p_{d\text{HF}} + \Delta p_{\text{HF}} = 30 \text{ mbar} + 13 \text{ mbar} = 43 \text{ mbar}$,
inlet pressure $p_{u\text{ absolute}}: 1.013 \text{ bar} + 0.043 \text{ bar}$
 $= 1.056 \text{ bar}$.

Outlet pressure for low fire $p_{d\text{LF}} = 0.3 \text{ mbar}$,
outlet pressure $p_{d\text{LF absolute}}: 1.013 \text{ bar} + 0.0003 \text{ bar} =$
 1.0133 bar .

Δp_{LF} for low fire:

$p_u - p_{d\text{LF}} = 43 \text{ mbar} - 0.3 \text{ mbar} = 42.7 \text{ mbar} = 0.0427 \text{ bar}$.

$$k_V = \frac{Q_n}{514} \cdot \sqrt{\rho_n \cdot T / (\Delta p_{\text{LF}} \cdot p_{d\text{LF absolute}})}$$

$$k_V = \frac{43}{514} \cdot \sqrt{\frac{1.293 \cdot 308}{0.0427 \cdot 1.0133}}$$

$$k_V = 8.03$$

Select a similar k_V value in the k_V values table for the BVH, BVHR, BVHS design. For a 10° opening angle, the selected k_V value is → $k_V = 12$.

After linear interpolation of the k_V values between 0 and 10°, the selected opening angle of the butterfly valve BVH for low fire is: $k_V = 8$ → approx. 6°.

The opening angle in the low-fire rate range should not be less than 2° in order to achieve good control properties.

Result

The opening angle for the butterfly valve BVH of DN 65 and control range 1:10 is 6° in the low-fire rate range and 76° in the high-fire rate range.

7 Project planning information

7.1 Installation

The butterfly valve must be installed in-between two flanges in accordance with EN 1092, PN 16.

The length of the inlet and outlet section should be $2 \times$ DN.

When designing the pipe, it is recommended that a flow velocity of 30 m/s (5905 ft/min) is not exceeded, see page 31 (Flow velocities in pipes).

Installation position

The actuator must be installed in the vertical or horizontal position, not upside down. BVHR: always position the actuator to the side of the pipe.

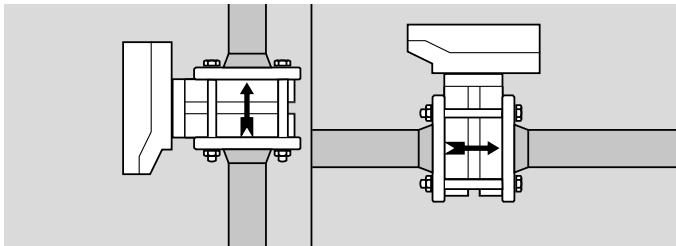

We recommend installing the butterfly valve in the vertical position with the direction of flow from bottom to top in order to prevent condensation and to prevent dirt from accumulating on the stop bar in the case of butterfly valves with stop bar.

If pipe fittings (reducing fittings) are installed in the pipework, the additional pressure loss must be taken into account.

Butterfly valves BVG, BVGF, BVA, BVAF, BVH, BVHR and BVHS and actuators IC are supplied separately or assembled. Easy assembly with the actuator using 2 screws can be carried out either before or after installation of the butterfly valve in the pipework.

The butterfly valve BVHM and the solenoid actuator MB 7 are delivered separately. Easy assembly with the solenoid actuator using the installation set can be carried out either before or after installation of the butterfly valve in the pipework.

Hot air as a medium

If the valve is used with hot air, the pipeline should be adequately insulated so as to reduce the ambient temperature – the flanges and the butterfly valve must be kept free of insulating material.

Install the butterfly valve in such a way that rising hot air does not circulate around the actuator.

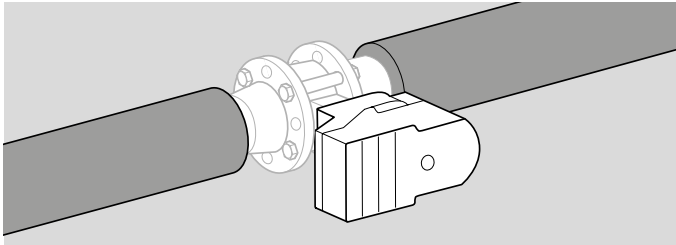

In conjunction with butterfly valves BVH, BVHS or BVHM for hot air, the actuators can be used in temperatures of up to 250°C (480°F), with additional heat deflectors they can be used in temperatures of up to 450°C (840°F).

Butterfly valve BVHR is available for medium temperatures of up to 550°C (1020°F). Always position the actuator to the side of the pipe. Installation in any other position would lead to the actuator being damaged due to high heat emissions. It is not necessary to install a heat deflector on the BVHR.

7.2 Flow velocities in pipes

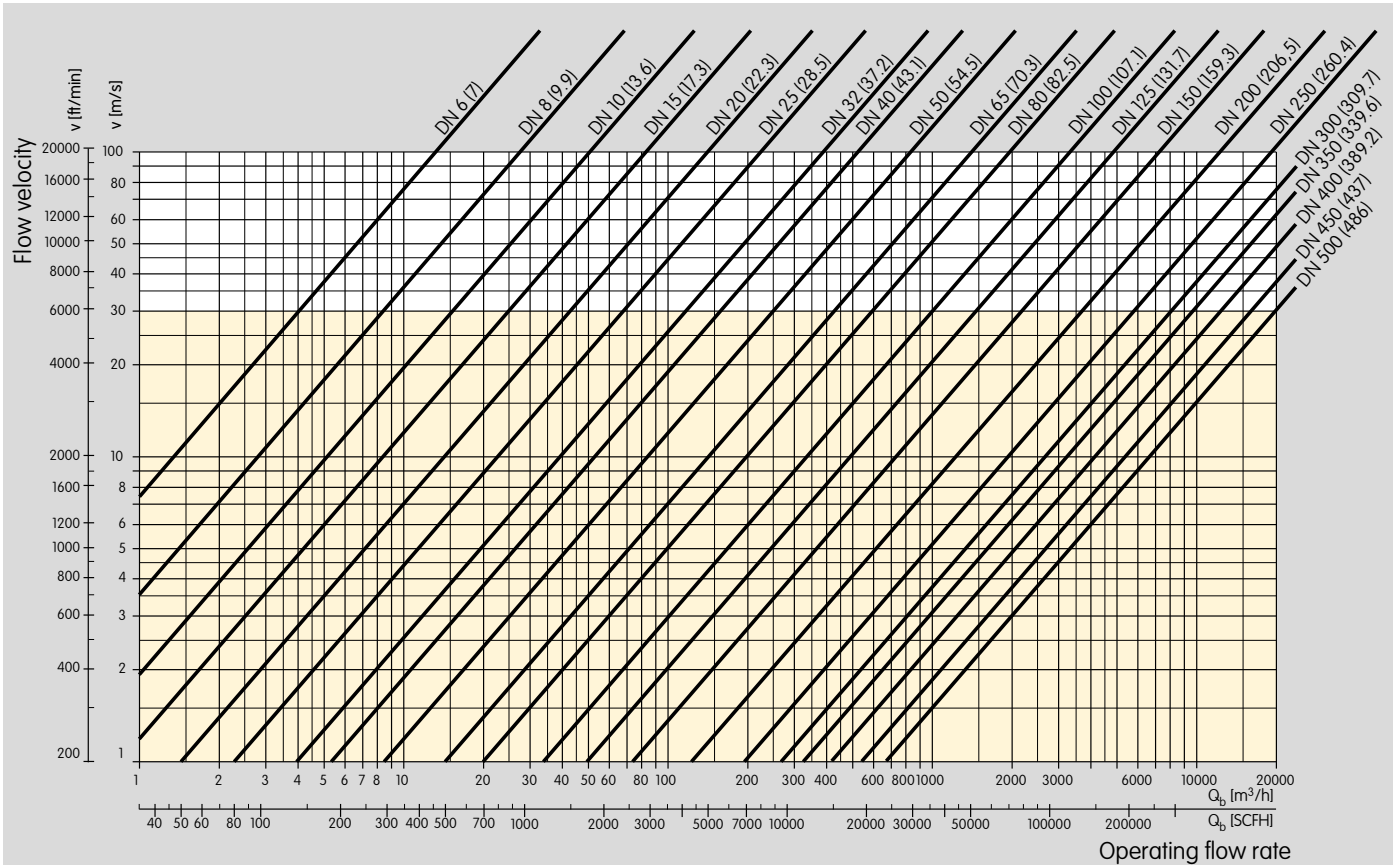

It is recommended that flow velocities of 30 m/s (5905 ft/min) are not exceeded when using the valve on thermoprocessing equipment.

The details on the internal diameter correspond to the

conventional dimensions for gas pipes as stipulated in the DIN standards DIN 2440 and DIN 2450. Different cross-sections will result in flow velocities that differ correspondingly.

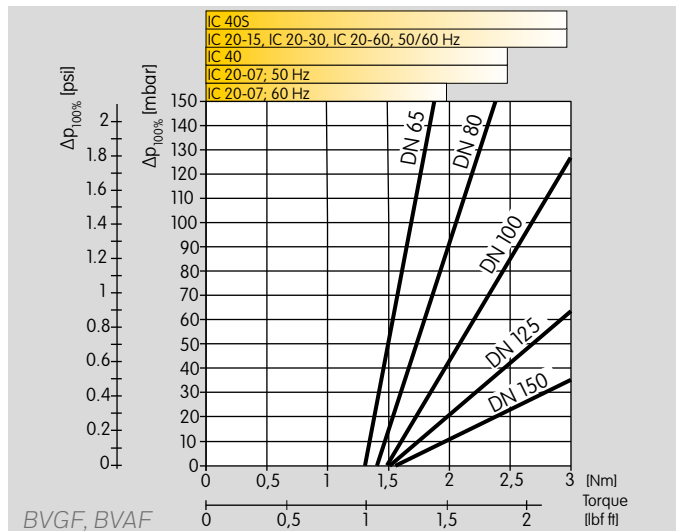
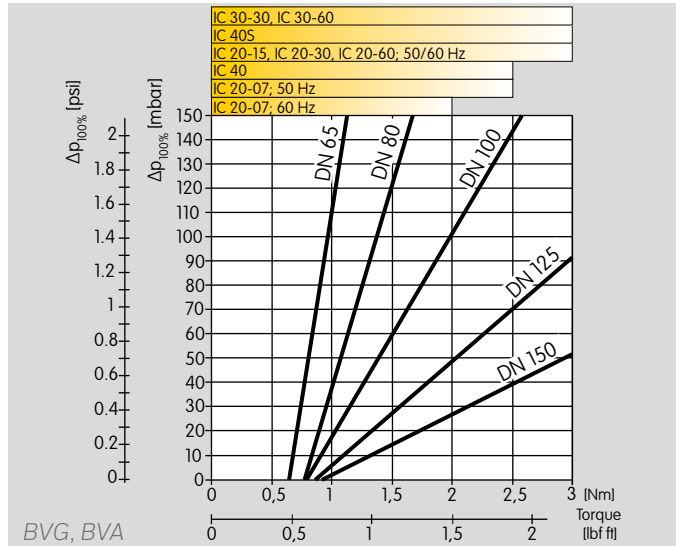

7.3 Actuator selection

Butterfly valves BVG, BVGF, BVA, BVAF, BVH and BVHR are controlled by actuator IC 20, IC 30 or IC 40.

Butterfly valve BVHS is controlled by actuator IC 40S.

Butterfly valve BVHM is controlled by solenoid actuator MB 7.

7.3.1 IC 20, IC 30, IC 40

The characteristic curves relate to the maximum torque produced by the flow rate. In general, maximum torque is reached at approx. 70°.

IC 20

The running time of the actuator per 90° depends on the required torque.

Example:

Any running time could be used for a butterfly valve BVG of nominal size DN 65.

The running time is reduced by a factor of 0.83 at a frequency of 60 Hz on the actuator.

IC 30

The running time changes depending on the load. It refers to the torque.

IC 40

Torque and running time are mutually independent on actuators IC 40 and IC 40S.



Project planning information

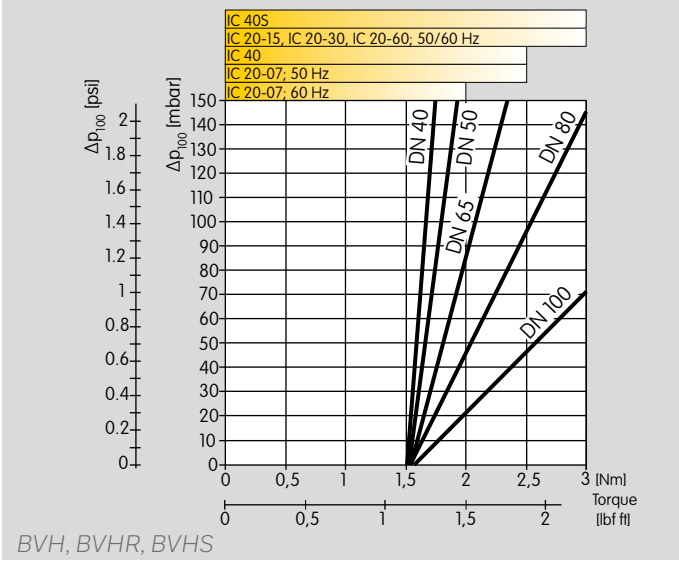

7.3.2 MB 7

MB 7..N: quick opening: < 1 s,

quick closing: < 1 s.

MB 7..R: slow opening: 2 – 4 s,

slow closing: 2 – 4 s.

MB 7..L: slow opening: 2 – 4 s,

quick closing: < 1 s.

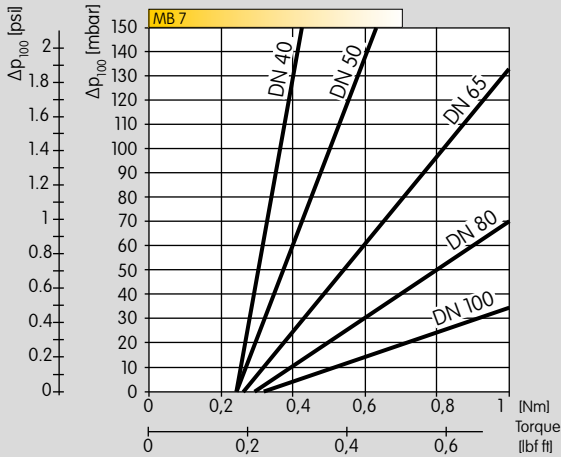

BVHM

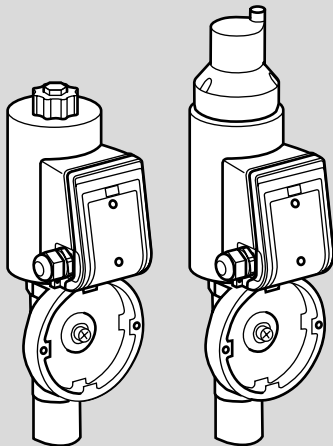

MB 7..N

MB 7..R, MB 7..L

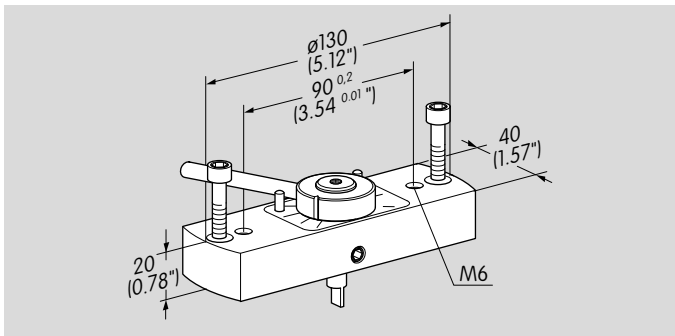
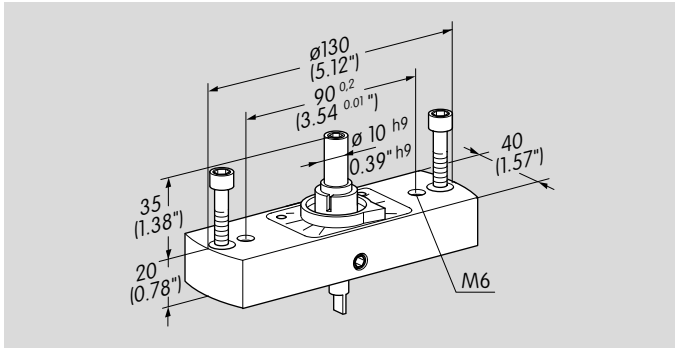
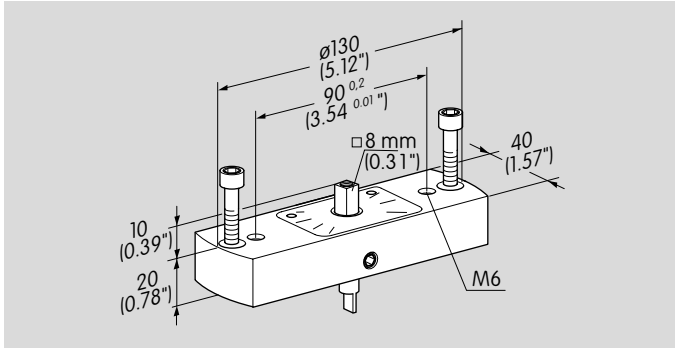

8 Accessories

8.1 Adapter set with square shaft

This adapter set is required if the butterfly valve BVG, BVA is mounted onto actuators other than IC. The actuator must have a square shaft end.

Adapter set	Order No.
Enclosed	74921674

8.2 Adapter set with free shaft end

This adapter set is required if the butterfly valve BVG, BVA is mounted onto actuators other than IC. The actuator must have a $\varnothing 10$ mm shaft end.

Adapter set	Order No.
Enclosed	74921676

8.3 Adapter set with manual adjustment

This adapter set is required if the butterfly valve BVG, BVA is to be opened and closed manually. The valve can be locked in position.

Adapter set	Order No.
Enclosed	74921678

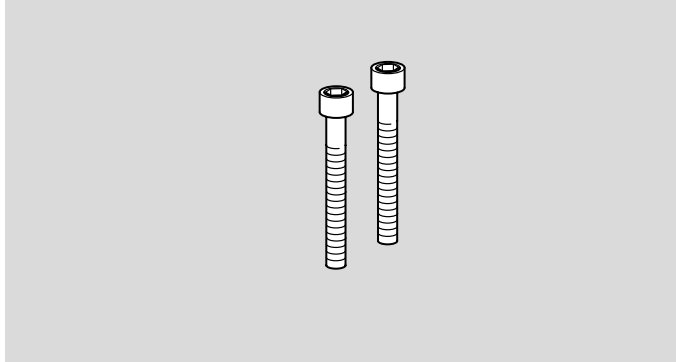

8.4 For BVG, BVGF, BVA, BVAF, BVH, BVHR, BVHS

Fastening set

To attach an IC 20 or IC 40 to the butterfly valve. If the actuator and butterfly valve are pre-assembled, the fastening set will already be fitted; otherwise, it will be enclosed as an additional item.

Fastening set	Order No.
IC - BVA/BVG/BVH /B (enclosed)	74921082

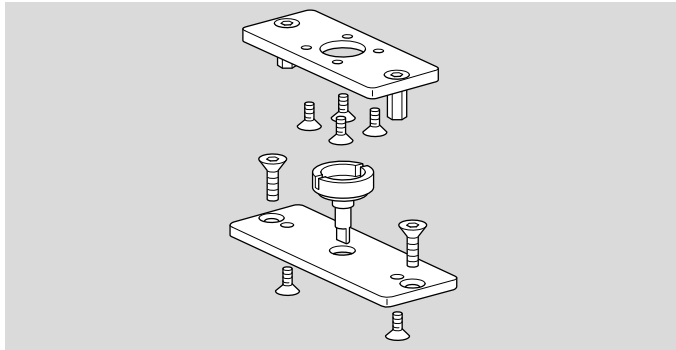

8.5 For BVG, BVA

Adapter set

To attach the IC 30 to the butterfly valve.

Order No.: 74924996.

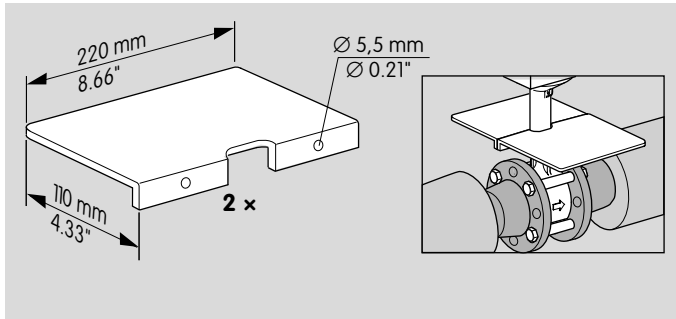

8.6 For BVH, BVHM and BVHS

Heat deflectors

Butterfly valves BVH, BVHM or BVHS for hot air can be used in temperatures of up to 250°C (480°F), with additional heat deflectors they can be used in temperatures of up to 450°C (840°F).

Order number: 74921670

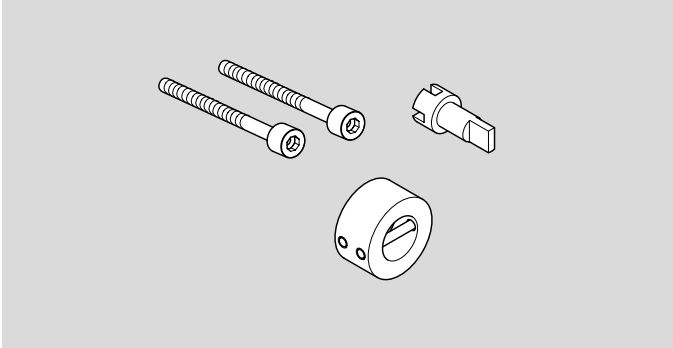

8.7 For BVHM

Fastening set

This is required to attach the solenoid actuator MB 7 to the butterfly valve BVHM. The fastening set is delivered enclosed as an additional item.

Order number: 74922222

9 Technical data

9.1 BVG, BVGF, BVA, BVAF

Gas type:

BVG, BVGF: natural gas, town gas, LPG, biogas (max. 0.1 %-by-vol. H₂S) and other non-aggressive fuel gases.

BVA, BVAF: air.

The gas must be dry in all conditions and must not contain condensate.

Housing material: AlSi,

valve disc: aluminium,

drive shaft: stainless steel,

seals: HNBR.

DN: 40 to 150, reduction by 2 nominal sizes is possible.

Inlet pressure p_U : max. 500 mbar (7.25 psi).

Ambient temperature:

-20 to +60°C (-4 to +140°F).

Medium temperature:

-20 to +60°C (-4 to +140°F).

Storage temperature:

-20 to +40°C (-4 to +104°F).

9.2 BVH, BVHR, BVHM, BVHS

Gas type: air and flue gas.

DN: 40 to 100.

Housing material: GGG,

valve disc: stainless steel,

drive shaft: stainless steel.

Inlet pressure p_U : max. 150 mbar (2.18 psig).

Pressure differential between inlet pressure p_U and outlet pressure p_d : max. 150 mbar (2.18 psig).

Ambient temperature:

-20 to +60°C (-4 to +140°F).

Medium temperature:

BVH: -20 to +450°C (-4 to +840°F),

BVHR: -20 to +550°C (-4 to +1020°F).

Storage temperature:

-20 to +40°C (-4 to +104°F).

9.3 Dimensions of IBG/IBA (BVG/BVA + IC 20/IC 40)

Type	H2	H3	DIN	ANSI	
	mm (inch)	mm (inch)	D1 mm (inch)	D1 mm (inch)	D2 mm (inch)
IBG/IBA 40	96 (3.78)	52 (2.05)	92 (3.62)	92 (3.62)	85.7 (3.37)
IBG/IBA 50	100 (3.94)	59 (2.32)	107 (4.21)	107 (4.21)	105 (4.13)
IBG/IBA 65	108 (4.25)	69 (2.72)	127 (5)	127 (5)	124 (4.88)
IBG/IBA 80	115 (4.53)	76 (2.99)	142 (5.59)	142 (5.59)	137 (5.39)
IBG/IBA 100	125 (4.92)	86 (3.39)	162 (6.38)	162 (6.38)	-
IBG/IBA 125	138 (5.43)	101 (3.98)	192 (7.56)	-	-
IBG/IBA 150	150 (5.9)	114 (4.49)	218 (8.58)	-	-

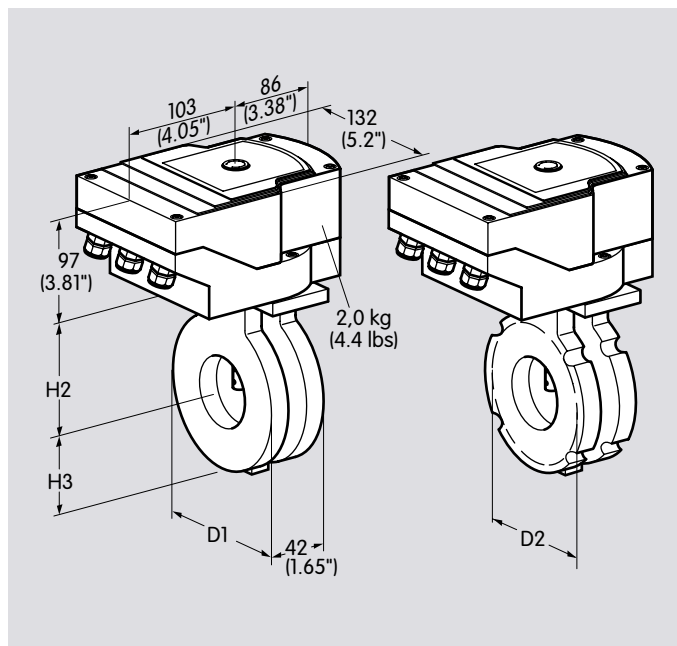

9.3.1 With full bore

Type	Weight
	kg (lbs)
IBG/IBA 40	2.7 (5.95)
IBG/IBA 50	2.8 (6.17)
IBG/IBA 65	3.0 (6.61)
IBG/IBA 80	3.2 (7.05)
IBG/IBA 100	3.3 (7.27)
IBG/IBA 125	3.6 (7.93)
IBG/IBA 150	3.9 (8.60)

9.3.2 With 1 × reduced bore

Type	Weight
	kg (lbs)
IBG/IBA 40/32	2.7 (5.95)
IBG/IBA 50/40	2.9 (6.39)
IBG/IBA 65/50	3.2 (7.05)
IBG/IBA 80/65	3.4 (7.49)
IBG/IBA 100/80	3.6 (7.93)
IBG/IBA 125/100	4.1 (9.04)
IBG/IBA 150/125	4.4 (9.70)

9.3.3 With 2 × reduced bore

Type	Weight
	kg (lbs)
IBG/IBA 40/25	2.8 (6.17)
IBG/IBA 50/32	3.0 (6.61)
IBG/IBA 65/40	3.2 (7.05)
IBG/IBA 80/50	3.5 (7.70)
IBG/IBA 100/65	3.8 (8.38)
IBG/IBA 125/80	4.4 (9.70)
IBG/IBA 150/100	4.9 (10.80)

9.4 Dimensions of IBGF/IBAF (BVGF/BVAF + IC 20/IC 40)

Type	H2	H3	ANSI		
	mm (inch)	mm (inch)	D1 mm (inch)	D1 mm (inch)	D2 mm (inch)
IBGF/IBAF 40	134 (5.28)	52 (2.05)	92 (3.62)	92 (3.62)	85.7 (3.37)
IBGF/IBAF 50	138 (5.43)	59 (2.32)	107 (4.21)	107 (4.21)	105 (4.13)
IBGF/IBAF 65	146 (5.74)	69 (2.72)	127 (5.00)	127 (5.00)	124 (4.88)
IBGF/IBAF 80	153 (6.02)	76 (2.99)	142 (5.59)	142 (5.59)	137 (5.39)
IBGF/IBAF 100	163 (6.41)	86 (3.39)	162 (6.38)	162 (6.38)	-
IBGF/IBAF 125	176 (6.93)	101 (3.98)	192 (7.56)	-	-
IBGF/IBAF 150	188 (7.40)	114 (4.49)	218 (8.58)	-	-

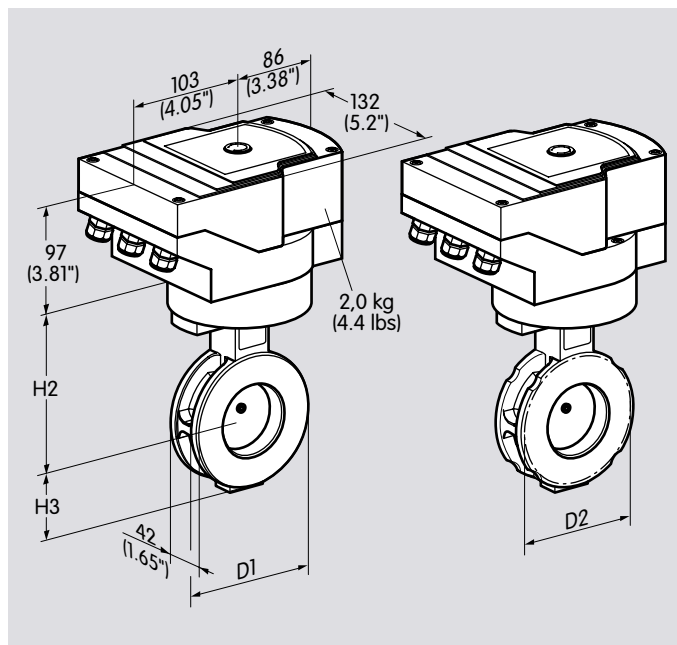

9.4.1 With full bore

Type	Weight
	kg (lbs)
IBGF/IBAF 40	3.5 (7.70)
IBGF/IBAF 50	3.6 (7.93)
IBGF/IBAF 65	3.8 (8.38)
IBGF/IBAF 80	4.0 (8.82)
IBGF/IBAF 100	4.1 (9.04)
IBGF/IBAF 125	4.4 (9.70)
IBGF/IBAF 150	4.7 (10.36)

9.4.2 With 1 × reduced bore

Type	Weight
	kg (lbs)
IBGF/IBAF 40/32	3.5 (7.70)
IBGF/IBAF 50/40	3.7 (8.16)
IBGF/IBAF 65/50	4.0 (8.82)
IBGF/IBAF 80/65	4.1 (9.04)
IBGF/IBAF 100/80	4.4 (9.70)
IBGF/IBAF 125/100	4.9 (10.80)
IBGF/IBAF 150/125	5.2 (11.46)

9.4.3 With 2 × reduced bore

Type	Weight
	kg (lbs)
IBGF/IBAF 40/25	3.6 (7.93)
IBGF/IBAF 50/32	3.8 (8.38)
IBGF/IBAF 65/40	4.0 (8.82)
IBGF/IBAF 80/50	4.3 (9.48)
IBGF/IBAF 100/65	4.6 (10.14)
IBGF/IBAF 125/80	5.2 (11.46)
IBGF/IBAF 150/100	5.7 (12.57)

9.5 Dimensions of BVG/BVA with IC 30

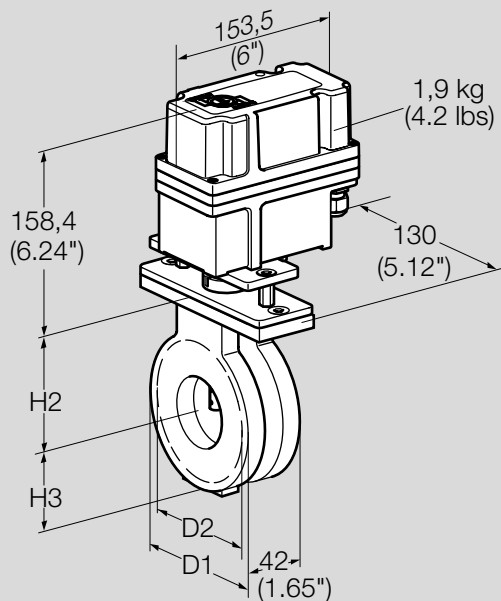

Type	H2	H3	DIN	ANSI	
	mm (inch)	mm (inch)	D1 mm (inch)	D1 mm (inch)	D2 mm (inch)
BVG/BVA 40 + IC 30	96 (3,78)	52 (2,04)	92 (3,62)	92 (3,62)	85,7 (3,37)
BVG/BVA 50 + IC 30	100 (3,94)	59 (2,32)	107 (4,21)	107 (4,21)	105 (4,13)
BVG/BVA 65 + IC 30	108 (4,25)	69 (2,72)	127 (5)	127 (5)	124 (4,88)
BVG/BVA 80 + IC 30	115 (4,53)	76 (2,99)	142 (5,59)	142 (5,59)	137 (5,39)
BVG/BVA 100 + IC 30	125 (4,92)	86 (3,39)	162 (6,38)	162 (6,38)	-
BVG/BVA 125 + IC 30	138 (5,43)	101 (3,98)	192 (7,56)	-	-
BVG/BVA 150 + IC 30	150 (5,9)	114 (4,49)	218 (8,58)	-	-

9.6 Dimensions of IBH/IBHS (BVH/BVHS + IC 20/IC 40)

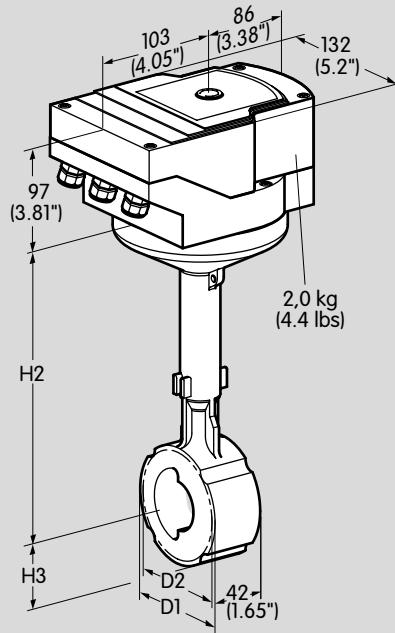

Type	H2	H3	DIN		ANSI		Weight
	mm (inch)	mm (inch)	D1 mm (inch)	D2 mm (inch)	D1 mm (inch)	D2 mm (inch)	kg (lbs)
IBH/IBHS 40	234 (9.2)	46 (1.8)	92 (3.6)	-	92 (3.6)	85.7 (3.4)	5.4 (11.9)
IBH/IBHS 50	239 (9.4)	54 (2.1)	107 (4.2)	-	107 (4.2)	105 (4.1)	5.9 (13.0)
IBH/IBHS 65	243 (9.5)	64 (2.5)	127 (5.0)	-	127 (5.0)	124 (4.9)	6.8 (15.0)
IBH/IBHS 80	254 (10)	71 (2.8)	142 (5.6)	-	142 (5.6)	137 (5.4)	7.3 (16.1)
IBH/IBHS 100	265 (10.4)	88 (3.4)	175 (6.9)	162 (6.4)	175 (6.9)	-	8.5 (18.7)

9.7 Dimensions of IBHR (BVHR + IC 20/IC 40)

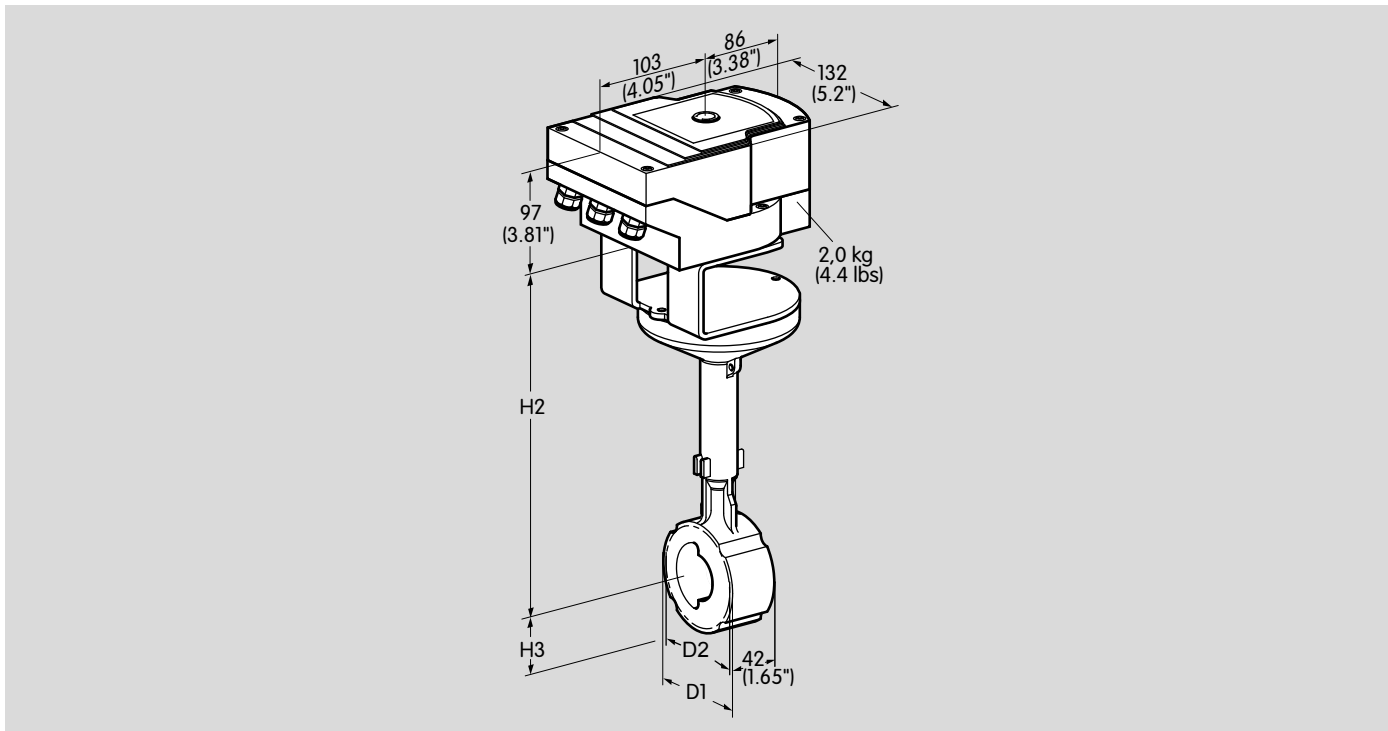

Type	H2	H3	DIN		ANSI		Weight
	mm (inch)	mm (inch)	D1 mm (inch)	D2 mm (inch)	D1 mm (inch)	D2 mm (inch)	kg (lbs)
IBHR 40	300 (11.8)	46 (1.8)	92 (3.6)	-	92 (3.6)	85.7 (3.4)	5,0 (11.0)
IBHR 50	305 (12.0)	54 (2.1)	107 (4.2)	-	107 (4.2)	105 (4.1)	5.6 (12.3)
IBHR 65	309 (12.2)	64 (2.5)	127 (5.0)	-	127 (5.0)	124 (4.9)	6.2 (13.6)
IBHR 80	320 (12.6)	71 (2.8)	142 (5.6)	-	142 (5.6)	137 (5.4)	6.7 (14.8)
IBHR 100	331 (13.0)	88 (3.4)	175 (6.9)	162 (6.4)	175 (6.9)	-	8.1 (17.7)

9.8 Dimensions of MB 7 + BVHM

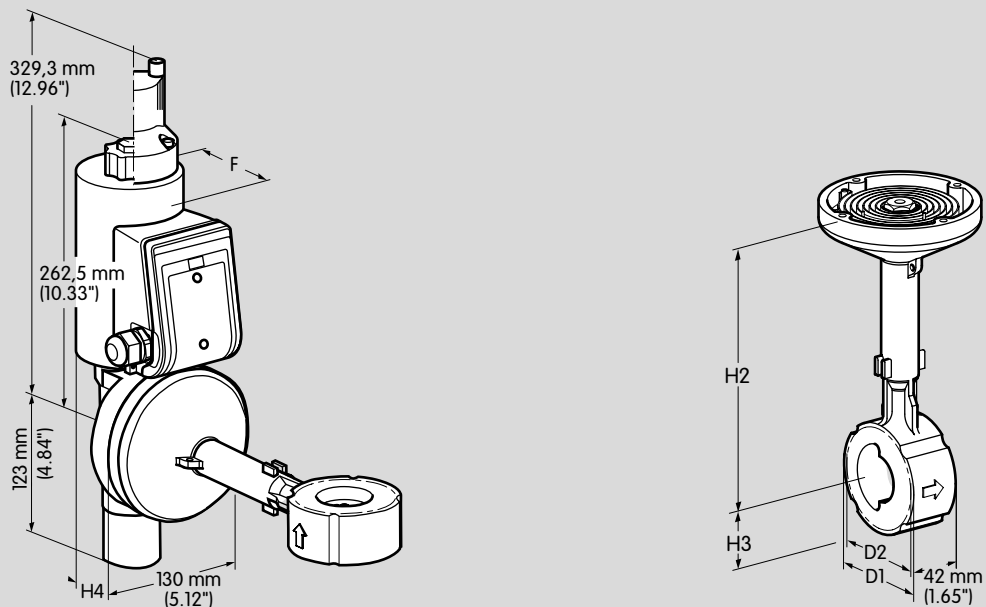

Type	H2	H3	H4	DIN		ANSI		F	Weight
	mm (inch)	mm (inch)	mm (inch)	D1 mm (inch)	D2 mm (inch)	D1 mm (inch)	D2 mm (inch)	mm (inch)	kg (lbs)
BVHM 40 + MB 7	234 (9.21)	46 (1.81)	91.5 (3.58)	92 (3.6)	-	92 (3.6)	85.7 (3.37)	92 (3.62)	11.79 (26.00)
BVHM 50 + MB 7	239 (9.40)	54 (2.12)	91.5 (3.58)	107 (4.2)	-	107 (4.2)	105 (4.13)	92 (3.62)	12.17 (26.83)
BVHM 65 + MB 7	243 (9.56)	64 (2.51)	91.5 (3.58)	127 (5.0)	-	127 (5.0)	124 (4.88)	92 (3.62)	13.05 (28.77)
BVHM 80 + MB 7	254 (10.00)	71 (2.80)	91.5 (3.58)	142 (5.6)	-	142 (5.6)	137 (5.39)	92 (3.62)	13.59 (29.96)
BVHM 100 + MB 7	265 (10.43)	88 (3.46)	91.5 (4.33)	175 (6.9)	162 (6.4)	175 (6.9)	-	92 (3.62)	14.97 (33.00)

10 Conversion factors

See www.adlatus.org

11 Maintenance cycles

Butterfly valves

The butterfly valves BVG, BVGF, BVA, BVAF, BVH, BVHR, BVHM and BVHS require little maintenance.

We recommend a function check once a year.

BVG, BVGF: check for external tightness once a year.

If operated with biogas, a tightness test and function check must be carried out every six months.

12 Glossary

12.1 Control characteristic, valve authority

In order for the butterfly valve to be able to influence the flow rate, a proportion of the pressure loss Δp from the entire system has to be caused by the butterfly valve. Taking into consideration that the overall pressure loss Δp , should be kept to a minimum, a valve authority $a = 0.3$ is recommended for the butterfly valve.

This means that of the overall pressure loss Δp there is a 30% drop on the fully open butterfly valve.

12.2 Interpolation (linear)

Mathematical production of interim values at equal distance to the adjacent value.

12.3 Hot air compensation

The volume of air increases with the addition of hot air. The oxygen content contained in the air reduces with every m^3 . In order to maintain a constant oxygen content, additional air has to be added to the combustion gas.

12.4 Symbols in acc. with DIN EN 334/14382 and DVGW G 491

Comparison of the new and old symbols

Name of the variable	Old	New
Inlet pressure	p_e	p_u
Outlet pressure	p_a	p_d

Feedback

Finally, we are offering you the opportunity to assess this “Technical Information (TI)” and to give us your opinion, so that we can improve our documents further and suit them to your needs.

Clarity

- Found information quickly
- Searched for a long time
- Didn't find information
- What is missing?
- No answer

Comprehension

- Coherent
- Too complicated
- No answer

Scope

- Too little
- Sufficient
- Too wide
- No answer



Use

- To get to know the product
- To choose a product
- Planning
- To look for information

Navigation

- I can find my way around
- I got “lost”
- No answer

My scope of functions

- Technical department
- Sales
- No answer

Remarks



Contact

Elster GmbH
Postfach 2809 · 49018 Osnabrück
Strohweg 1 · 49504 Lotte (Büren)
Germany

Tel +49 541 1214-0
Fax +49 541 1214-370
info@kromschroeder.com
www.kromschroeder.com

The current addresses of our international agents
are available on the Internet:
www.kromschroeder.de/Weltweit.20.0.html?&L=1

We reserve the right to make technical
modifications in the interests of progress.
Copyright © 2017 Elster GmbH
All rights reserved.

