

---

# HON – C210 Series Pressure Control Valve

## Mounting & Operating Instructions

---

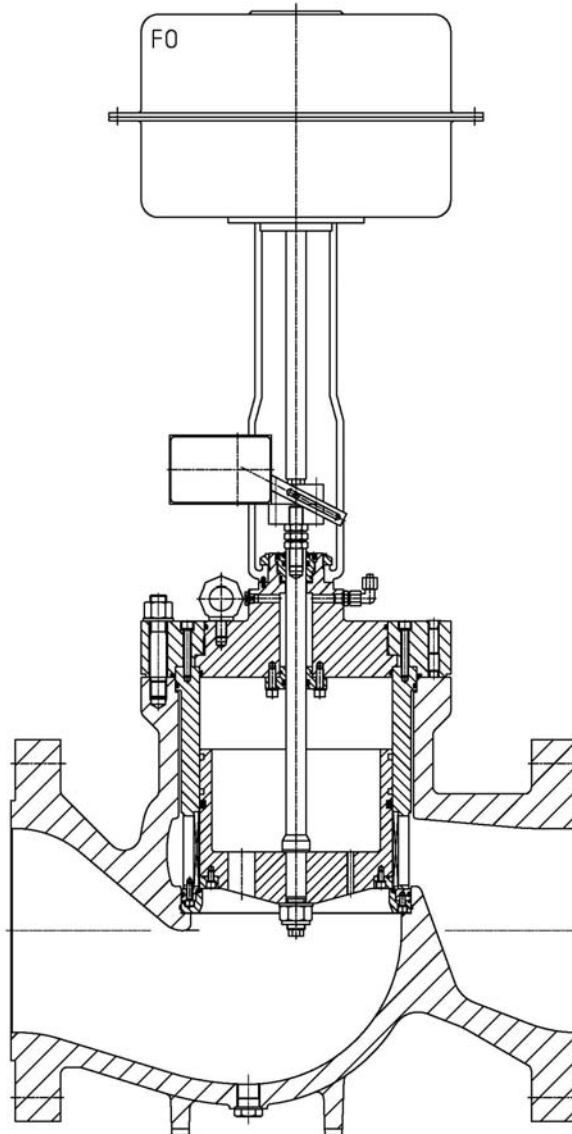

Honeywell Process Solutions  
Honeywell Gas Technologies GmbH  
Osterholzstr. 45, 34123 Kassel, Germany  
+49 (0)561 5007-0 (General)  
[www.honeywellprocess.com](http://www.honeywellprocess.com)

Number : 80.98.33.05.03.01.0  
Revision : A  
August 2018

## Contents

<b>0.Introduction</b>	<b>3</b>
<b>1.Description</b>	<b>3</b>
1.1 Model type	3
1.2 Technical specifications	4
1.3 Material	4
1.4 Dimensions	5
1.4.1 Dimensions for HON C210S(M) with pneumatic actuator	5
1.4.2 Dimensions for HON C210S(M) with electrical actuator	7
1.5 Weight approx. (kg)	8
1.6 Technical data for actuator/positioner	8
1.6.1 Pneumatic actuator	8
1.6.2 Electrical actuator	9
<b>2.Instructions for control valve with pneumatic actuator</b>	<b>10</b>
2.1 Design and principle of operation	10
2.2 Installation	12
2.2.1 Assembly	12
2.2.2 Mounting position	13
2.2.3 Signal pressure line	13
2.2.4 Filter, strainer and bypass	13
2.2.5 Lubrication	13
2.3. Operation	13
2.3.1 Pneumatic actuator	13
2.3.2 Valve positioner	14
2.3.3 Air connections	15
2.3.4 Converting from pneumatic positioner to electronic control signal	17
<b>3.Maintenance</b>	<b>18</b>
3.1 General	18
3.2 Maintenance requirements	18
-Lubricants:	18
- Oil:	18
-Adhesive:	19
Recommended bolt preload on pressurized parts:	20
3.3 Spare-part sets	22
<b>4.Trouble-shooting</b>	<b>22</b>
Valve Body	22
HON C210S 6"150/600 Main Parts List	26
HON C210SM 6"150/600 Main Parts List	28
HON C210S 12"150/600 Main Parts List	30
HON C210SM 12"150/600 Main Parts List	32

Despite the care taken while composing the text and illustrations, Honeywell does not accept liability for any inaccuracies.

## 0. Introduction

- **Trained personnel**
- According to these mounting and operating instructions, trained personnel is referred to as persons who are able to judge the work they are assigned to and recognize possible dangers due to their knowledge of the pertinent standards.
  
- **Appropriate measures**
- Any hazards which could be caused by the process medium, the signal pressure and moving parts of the control valve are to be prevented by means of appropriate measures.
  
- **Valve sizing data**
- In addition, it is required to make sure that the control valve is only used in areas where the operating pressure and temperatures do not exceed the operating values which are based on the valve sizing data submitted in the order.
  
- **Shipping and storage**
- Proper shipping and appropriate storage are assumed

## 1. Description

### 1.1 Model type

HON C210 valve type	HON C210S Standard version	HON C210S-M Monitor version
Actuator type	Pneumatic actuator Electrical Actuator	Pneumatic actuator
<p><b>Pneumatic actuated C210S</b>                      In normal operational condition, the monitor is fully open, and the active valve is regulating. Should the active valve fail it will fully open on spring force, and the monitor will take over the regulation. Should the monitor then fail also, it will close on spring force, interrupting the flow and preventing the downstream pipe from damage from over pressurizing.</p> <p><b>Electrical actuated C210S</b>                      Normally the electrical actuated C210S-E is not used in a Monitor – Active configuration. When there is power loss, the valve will stay on its position. When there is only signal loss the valve can be programmed to close, open or remain on its position. Power or signal loss normally occur on both monitor and active and therefore seem not useful. The Monitor Active configuration is used as combination of an active pressure regulator R100S-M with the active control valve C210S-E. In this way pressure and flow are controlled.                      The electrical actuators are standard to be used for 400V/3F/50Hz and controlled via 4-20 mA. Anything that differs from the above needs to be addressed as ETO (Engineered to Order). A project specific actuator than needs to be defined by the manufacturer of the electric actuator.</p> <p><b>General</b>                      The S in C210S stands for “silenced”. Standard the valve has a silencer that reduces flow noise to an acceptable level.</p>		

## 1.2 Technical specifications

Pressure categories	: ANSI class 150 / class 300 / class 600
Design	: EN 334, EN 1349, EN 12516, ANSI B16.10
Connection pressure	: Up to 100bar (EN) 103.4bar (ANSI)
Temperature range	: -20 up to +60°C
Medium	: Natural Gas
Accuracy	: up to Ac = 1

## 1.3 Valve Material

Valve body / Cover	: A 352-LCC, S355J2G3, P355NH or A350LF2 (steel 3.1 certified)
Valve shank	: 17-4 PH cond. H1150+1150
Guide	: CuAl10Ni
Other internal parts	: Mainly steel
O-ring	: NBR

## 1.4 Dimensions

### 1.4.1 Dimensions for HON C210S (M) with pneumatic actuator

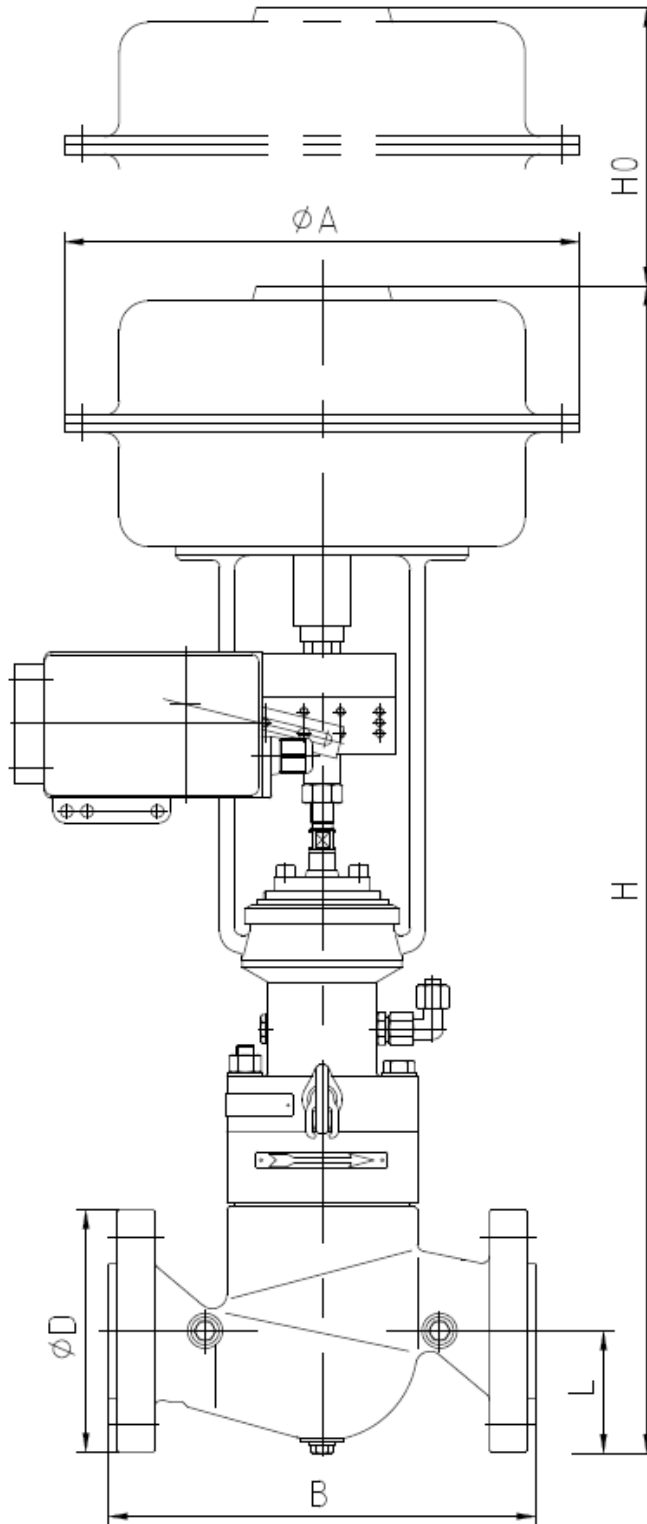

Fig.1 Dimensional drawing HON C210 with pneumatic actuator

HON C210 series

Type(RF)	A mm	B mm	D mm	L mm	H mm	H0 mm ( <i>minimum clearance for removing actuator</i> )
2" cl.300	352	267	165	86	799	250
2" cl.600	352	292	165	84	797	
3" cl.300	405	318	210	105	868	
3" cl.600	405	356	210	105	868	
4" cl.300	405	356	254	127	907	
4" cl.600	405	432	273	136.6	917	
6" cl.300	548	445	318	158.8	1270	300
6" cl.600	548	559	356	177.8	1289	
8" cl.300	548	559	381	224	1419	
8" cl.600	548	660	419	229	1424	
10" cl.600	548	787	508	270	1535	
12" cl.300	548	838	521	320	1603	
12" cl.600	548	838	559	320	1603	

Table.1 Dimensions HON C210 with pneumatic actuator

### 1.4.2 Dimensions for HON C210S (M) with electrical actuator

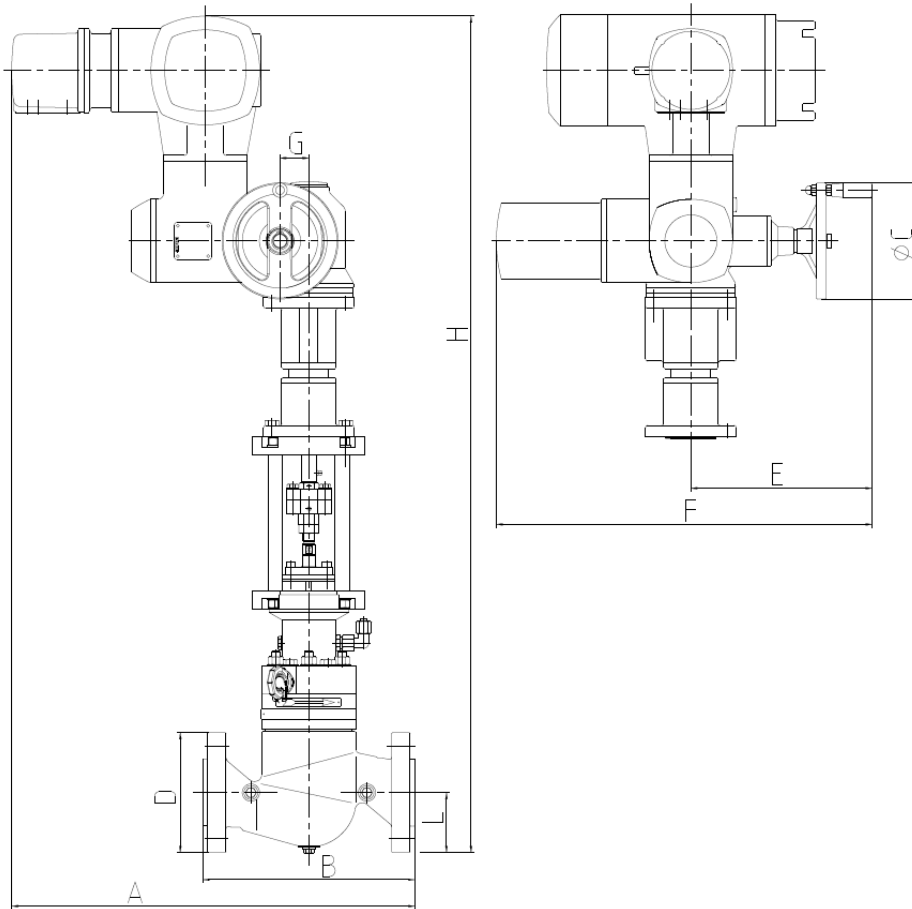

Fig.2 Dimensional drawing HON C210S with electrical actuator

Type(RF)	A	B	C	D	E	F	G	L
2" cl.300	543.5	267	160	165.1	249	517	40	86
2" cl.600	556	292	160	165.1	249	517	40	84
3" cl.300	569	318	160	210	249	517	40	105
3" cl.600	588	356	160	210	249	517	40	105
4" cl.300	588	356	160	254	249	517	40	127
4" cl.600	626	432	160	273.1	249	517	40	136.55
6" cl.300	642.5	445	200	317.5	254	537	50	158.75
6" cl.600	699.5	559	200	355.6	254	537	50	177.8
8" cl.300	699.5	559	200	381	254	537	50	224
8" cl.600	750	660	200	419.1	254	537	50	229
10" cl.600	813.5	787	200	508	254	537	50	270
12" cl.300	839	838	200	521	254	537	50	320
12" cl.600	839	838	200	559	254	537	50	320
16" cl.300	453	990	315	648	242	631	67	404
16" cl.600	453	990	315	686	242	631	67	404

Table.2 Dimensions HON C210S with electrical actuator

**1.5 Weight approx. (kg)**

Type	2"	3"	4"	6"	8"	10"	12"	16"
C210 with pneumatic actuator	80	110	160	255	365	800	1060	X
C210 with electrical actuator	92	111	161	180	290	725	985	1174

Table.3 Weight HON C210 series

**1.6 Technical data for actuator/positioner**

**1.6.1 Pneumatic actuator**

	Size	2"	3"	4"	6"	8"	10"	12"
Standard model type* (Flowserve)		PB 502	PB 700	PB 700	PB 1502	PB 1502	PB 1502	PB 1502
Controlled variable travel	mm	40	40	40	80	100	100	100

Table.4 Technical data of actuator

\*Other specific actuator's type can be ordered on request.

Customer inquiries

Please submit the following details for the Valve with Actuator:

- 1 Order number
- 2 Model
- 3 Fail close/ Fail open
- 4 Flow direction (position of the operator)
- 5 Pressure and temperature of the process medium
- 6 Flow rate
- 7 Has a filter, strainer been installed?
- 8 Installation drawing
- 9 Control signal



## 1.6.2 Electrical actuator

Type(RF)	A mm	B mm	D mm	L mm	H mm	H0 mm ( <i>minimum clearance for removing actuator</i> )
2" cl.300	352	267	165.1	86	799	250
2" cl.600	352	292	165.1	84	797	
3" cl.300	405	318	210	105	868	
3" cl.600	405	356	210	105	868	
4" cl.300	405	356	254	127	907	
4" cl.600	405	432	273.1	136.55	917	
6" cl.300	548	445	317.5	158.75	1270	300
6" cl.600	548	559	355.6	177.8	1289	
8" cl.300	548	559	381	224	1419	
8" cl.600	548	660	419.1	229	1424	
10" cl.600	548	787	508	270	1535	
12" cl.300	548	838	521	320	1603	
12" cl.600	548	838	559	320	1603	

Table.5 Technical data of actuator

\*Other specific actuator's type can be ordered on request.

### Customer inquiries

Please submit the following details for the Valve with Actuator:

- 1 Order number
- 2 Model
- 3 Power supply, 400V/3F/50Hz (Standard version)
- 4 Flow direction (position of the operator)
- 5 Pressure and temperature of the process medium
- 6 Flow rate
- 7 Has a filter, strainer been installed?
- 8 Installation drawing
- 9 Control signal

The standard electrical actuator used is Auma.

The electrical actuator can be delivered with many different specifications.

There are many considerations and options to be cleared before a suitable type is determined.

Power supply differs in different regions of the world and needs a specific motor.

The control signal can be Field Bus, Hart or any other digital signal, and needs to be addressed in the quotation phase.

A redundant power source may be installed and out coming signals for position and alarms need to be defined.

Detailed documentation can be obtained from Auma after the wiring and connections are determined.

## 2. Instructions for control valve with pneumatic actuator

### 2.1 Design and principle of operation

The type HON C210S M) Pneumatic Control Valve consists of a single seated globe valve and a pneumatic actuator. The process medium flows through the valve in the direction indicated by the arrow. The position of the plug (32) is adjusted by changing the signal pressure acting on the diaphragm of the actuator (67). The plug stem (2) together with the plug is connected to the actuator stem (67.1) via the stem connector (67.2) and is sealed with O-ring seals (13).

#### **Fail-safe action:**

Depending on the arrangement of the compressed spring in the actuator, there are two different fail safe actions:

**a. Actuator stem extends \_ Fail close**

Whenever the signal pressure decreases or the supply air fails, the spring moves the actuator stem downwards, closing the valve.

The valve opens with increasing signal pressure against the force of the spring.

**b. Actuator stem retracts \_ Fail open**

Whenever the signal pressure decreases or the supply air fails, the spring moves the actuator stem upward, opening the valve.

The valve closes with increasing signal pressure against the force of the spring.

HON C210 series

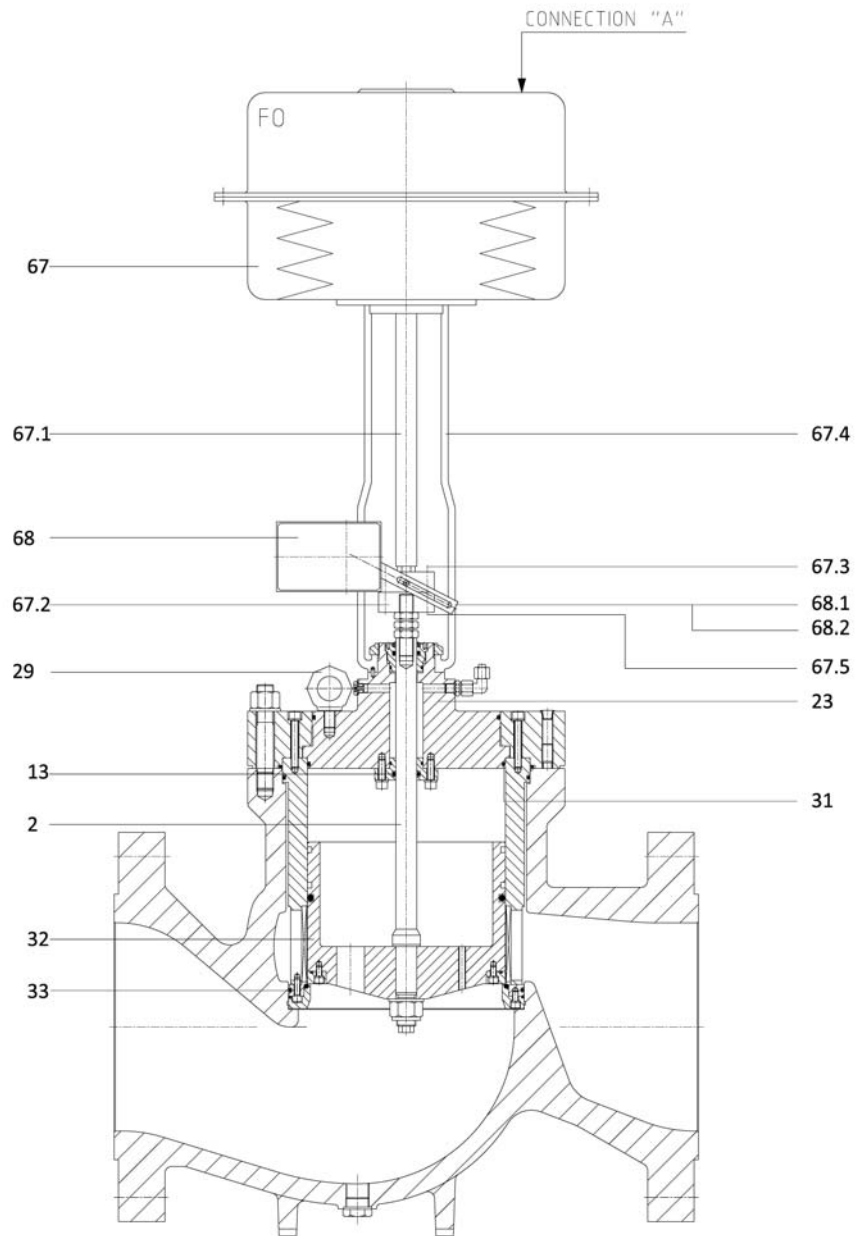

Fig.3 HON C210S (12"150/600)

## 2.2 Installation

### 2.2.1 Assembly

#### 2.2.1.1 Assembling valve and the actuator

**Note on disassembly:**

When disassembling the actuator and in particular when using version with pre-tensioned springs, a pressure slightly lower than the upper value of the bench range must be applied to the signal pressure connection (A).

**Assembly and adjustment**

- Remove the clamps of the stem connector (67.3) and the ring nut (1).
- Place the yoke with the actuator (67.4) on the valve bonnet (4) and screw tight using the ring nut (1).

For actuators with 'Actuator stem retracts' vent the actuator.

Attach the clamps (67.3) on both the plug stem (2) and the actuator stem (67.1).

- Apply a pressure corresponding to the upper signal pressure range (4 bar) to the signal pressure location located at the top diaphragm chamber (A).
- Turn the clamp of the valve stem (67.3) by hand until it contacts the clamp of the actuator stem.
- Vent the actuator a little and turn the lower clamp approx. 1 turn further.
- Pressurize again and screw tight the clamps using the bolts (67.5).

Subsequently attach the valve positioner (68), lever (68.1), lever pin (68.2) and signal lines.

Take care to keep the proper arrangement.

#### 2.2.1.2 Assembling valve body and the bonnet including actuator

**Important:**

The lifting lugs positioned at the valve bonnet (4) can be used for lifting purposes (Taking care not to damage the actuator)!

Thoroughly clean the valve body and grease (with Staburags N 32) the sealing areas (located at the seat and bonnet flange)

It is recommended to replace the bonnet sealing ring (26)

- Check the sealing ring (33) of the guiding bush for damage or impurities. If not then grease it well (Staburags N 32) before placing the bonnet onto the valve body.
- Grease the stud bolts incl. nuts (7) and (10) with Molykote copper grease.
- Place the bonnet onto the bonnet flange of the valve body using the upper lifting lugs
- Slightly turn and lower the bonnet while controlling its alignment with the valve body.
- Tighten the nuts cross-wise.

## 2.2.2 Mounting position

The valve should preferably be mounted vertically with the actuator pointing upwards. This will facilitate maintenance and enable better lubrication. The valve must be installed free of stress. If needed, support the pipelines near the connections. Do not attach any supports on the valve or on the actuator.

**Important:**

Thoroughly flush the pipelines prior to installing the valve.

## 2.2.3 Signal pressure line

For valves with fail safe action 'Actuator stem retracts' connect the signal pressure line to the top diaphragm chamber.

## 2.2.4 Filter, strainer and bypass

For proper operation, the gas should be filtered up to 40µm. Furthermore, it is recommended to install a strainer upstream of the valve. Ideally a bypass together with shut-off valves should be installed to be able to remove the control valve from the pipeline for maintenance procedures.

## 2.2.5 Lubrication

See 4.2

## 2.3. Operation

### 2.3.1 Pneumatic actuator

The signal pressure produces a force acting on the surface of the diaphragm which is balanced by the compression springs in the actuator. The spring compression and the diaphragm area determine the signal pressure range related to the travel, where the travel is directly proportional to the signal pressure.

Whenever the signal pressure fails, the spring load in the top diaphragm chamber determines the fail-safe action of the actuator. As result the closure member of the attached valve is moved in the appropriate fail-position. This version features 'Actuator retracts' which equals a 'fail-open' position.

For actuator action 'Actuator stem retracts' the actuator loading pressure is introduced to the top diaphragm chamber via the signal pressure connection, serving to move the actuator stem (67.1) in a downward direction.

With respect to Model HON C210S (including positioner attachment) with an effective diaphragm area of 1500 cm<sup>2</sup>, the actuator loading pressure is introduced to the diaphragm chamber via the positioner. The signal pressure has a bench range of approx. 2.0 to 3.5 bar.

## 2.3.2 Valve positioner

### (Working principle of analogue type - example-)

The pneumatic positioner is used to guarantee a pre-selected correspondence between the valve stem position (controlled variable) and the supplied instrument input signal (reference variable). In this process, the instrument signal  $P_e$ , supplied by a control device is compared to the travel of the control valve resulting in a pneumatic signal (output variable  $P_{st}$ ) which is supplied to the actuator.

The positioner essentially consists of a lever (45) and measuring spring (46), the measuring diaphragm (47) and the pneumatic control system comprising nozzle (48), flapper plate (49) and amplifier (booster) (50).

The positioner operates according to the forced-balance principle. In this way, the stroke of the actuator stem or the plug stem (controlled variable) is transmitted to the lever (45) and the measuring spring (46). This action varies the spring force.

The instrument input signal ( $P_e$ ) supplied by the connected controller as reference variable produces a positioning force on the measuring diaphragm (47), this force of which is compared with the force of the measuring spring (46). At the same time, the motion (deflection) of the measuring diaphragm is transmitted to the flapper plate (49) thereby releasing pressure from the nozzle (48).

Any changes of the instrument input signal  $P_e$  or the valve stem position cause a pressure variation given to the amplifier. The air released by the amplifier (signal pressure  $P_{st}$ ) flows to the pneumatic actuator via the volume restrictor (51), causing the plug stem to take on a position corresponding to the reference input variable.

Supply air is piped to the pneumatic amplifier (50) and flows through the  $X_p$  adjustment (52) and the nozzle (48) until it hits the flapper plate (49).

The adjustable tuning throttles (51 and 52) are used to optimize the control loop.

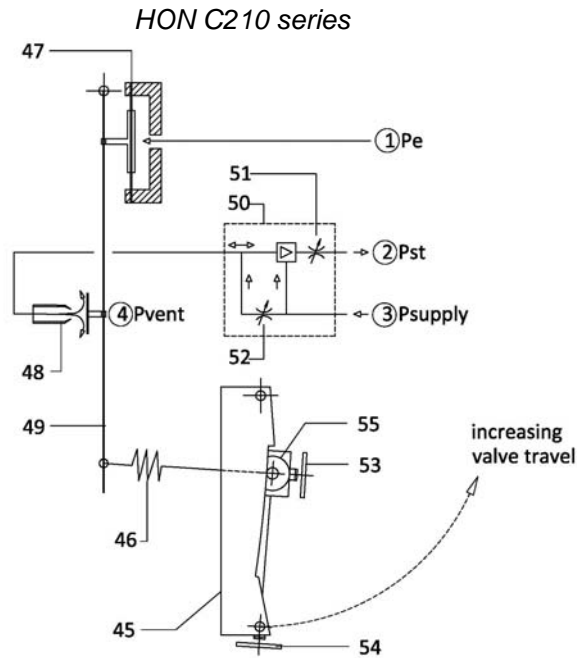

Fig. 6 Schematic diagram of the valve position

### 2.3.3 Air connections

#### (Working principle of analogue type - example-)

##### Note

'Air' = common used designation for air and other gas (-mixtures) suitable for pneumatic actuation of PCV's.

The air connections are designed with tapped holes. Common male unions can be used. Supplied air may need special conditioning apart from 'common practice', consult relevant manuals.

##### Important

- Before commissioning, the positioner (connection 4) must be provided with a vent line!
- Always observe the maintenance instructions applicable to the up-stream pressure reducing station
- Thoroughly blow through the air lines before connecting.

The positioner output signal is introduced as loading pressure to the top actuator for actuator action 'Actuator retracts', the supply air should be adjusted to the maximum allowable force with respect to the actuator (6 bar).

HON C210 series

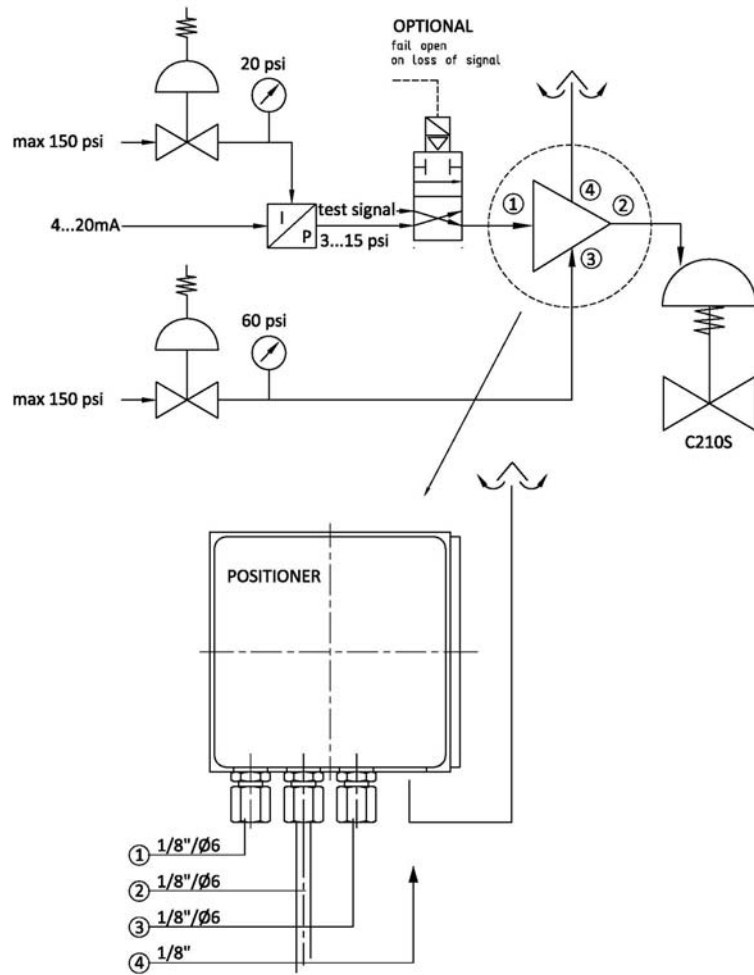

Fig. 7 Air connections (example)



### 2.3.4 Converting from pneumatic positioner to electronic control signal

The pneumatic positioner can be controlled with an input signal of 4 to 20 mA using a corresponding I/P convertor.

An instrumentation scheme is shown in Fig.8

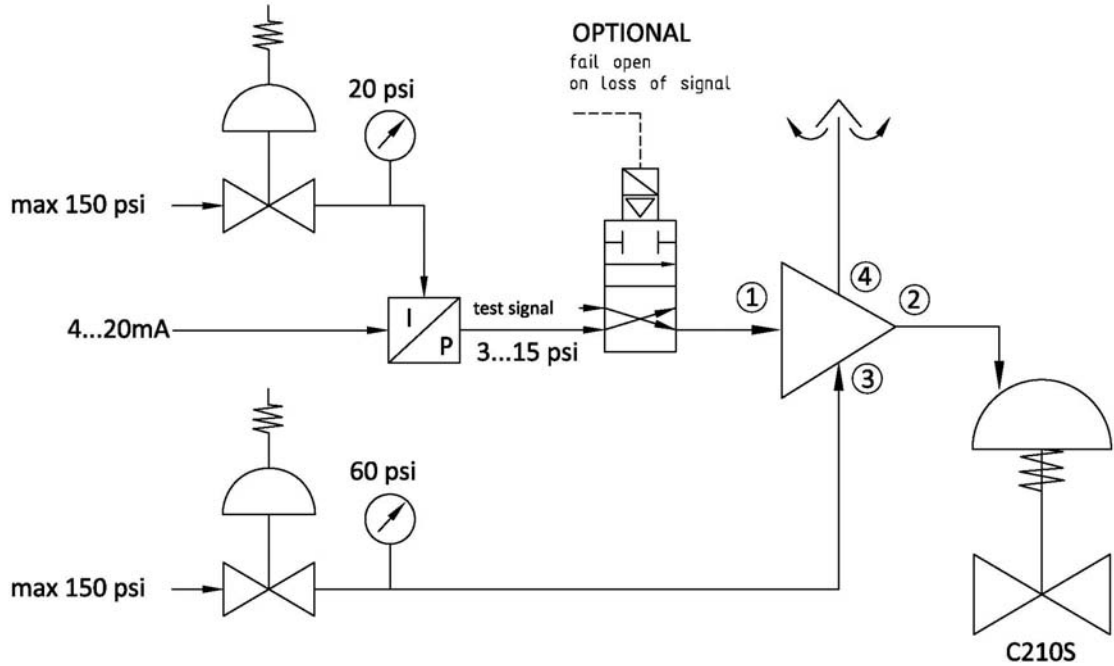

Fig. 8 Instrumentation schematic

### 3. Maintenance

#### 3.1 General

To all dynamic O-rings (seals between the moving parts), for optimal working, a recommended maximum life of 4 years. For static O-rings (seals between fixed, non-moving parts) Honeywell advises a useful life of 6 to 7 years.

You can find all required parts for maintenance work in the parts list added.

#### 3.2 Maintenance requirements

Honeywell equipment has been designed in such a way that no special tools are required for maintenance.

Valves are provided with tapped holes to which simple pulling tools may be connected.

#### -Lubricants:

Mind the following during all maintenance work:

- Unless otherwise indicated, all screw connections < M10 are to be greased with a suitable grease (Honeywell advises MOLYKOTE BR2 PLUS). Screw connections > M10 are to be greased with copper grease (Honeywell advises APPLIED 1-280 COPPER GREASE or MOLYKOTE KOPER PASTA).
- All O-rings are to be greased with a suitable grease (Honeywell advises Staburags N 32 or Parker Super-O-Lube).
- All guiding surfaces are to be greased with a suitable grease (Honeywell advises Staburags N 32 or Parker Super-O-Lube).

#### - Oil:

Shell Gas Compressor Oil S4 RN 68 (previously known as Shell Madrela GS 68)

On the top flange a connection (21) is installed to fill the 'stuffing chamber' of the plug stem packing (13) with oil. Ideal is a silicone based oil to diminish friction and stick-slip effects. In any case the oil should be acid-free. After installation apply a little of this oil via connection (21). In order to introduce some oil unscrew the socket head plug (21).

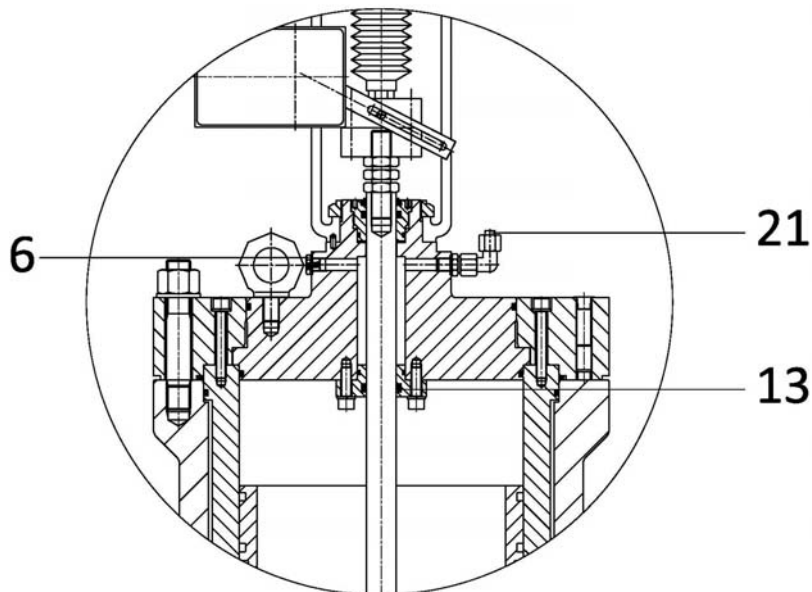

Fig.9 Connection for lubrication of the plug stem

HON C210 series

-Adhesive: Loctite 243

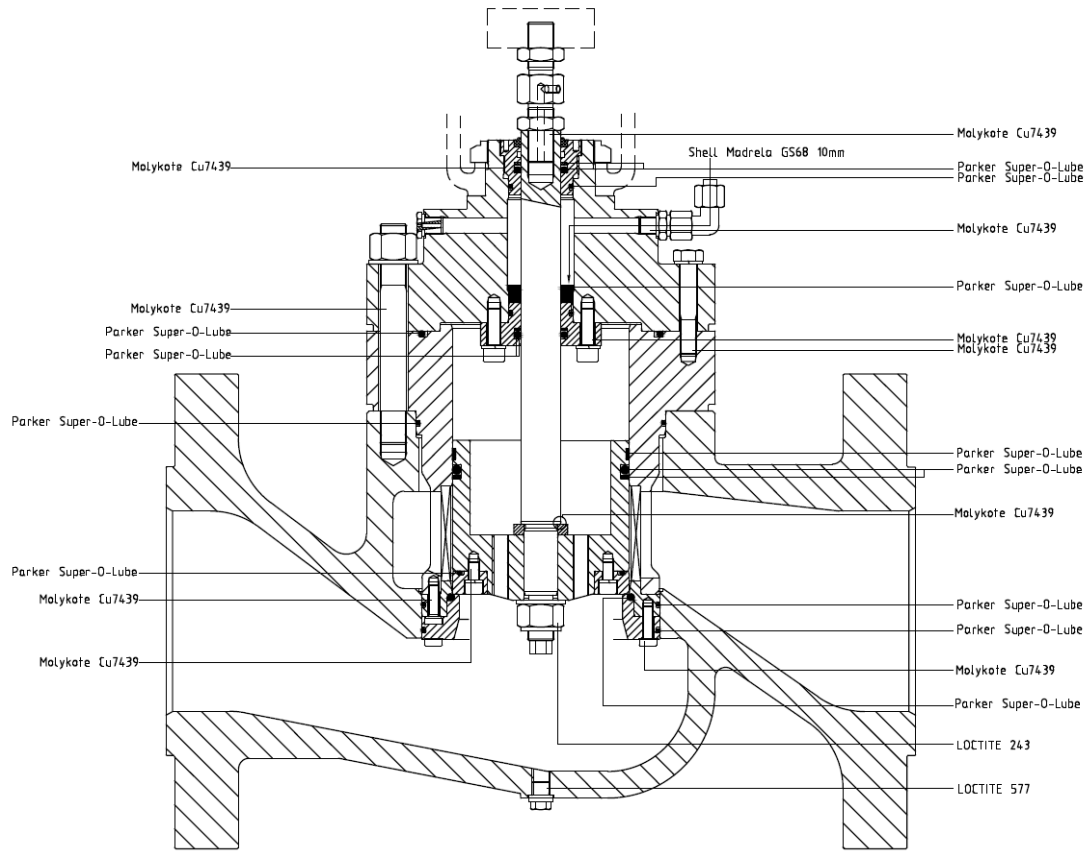

Fig.10 Lubricants and sealants drawing for HON C210S

## HON C210 series

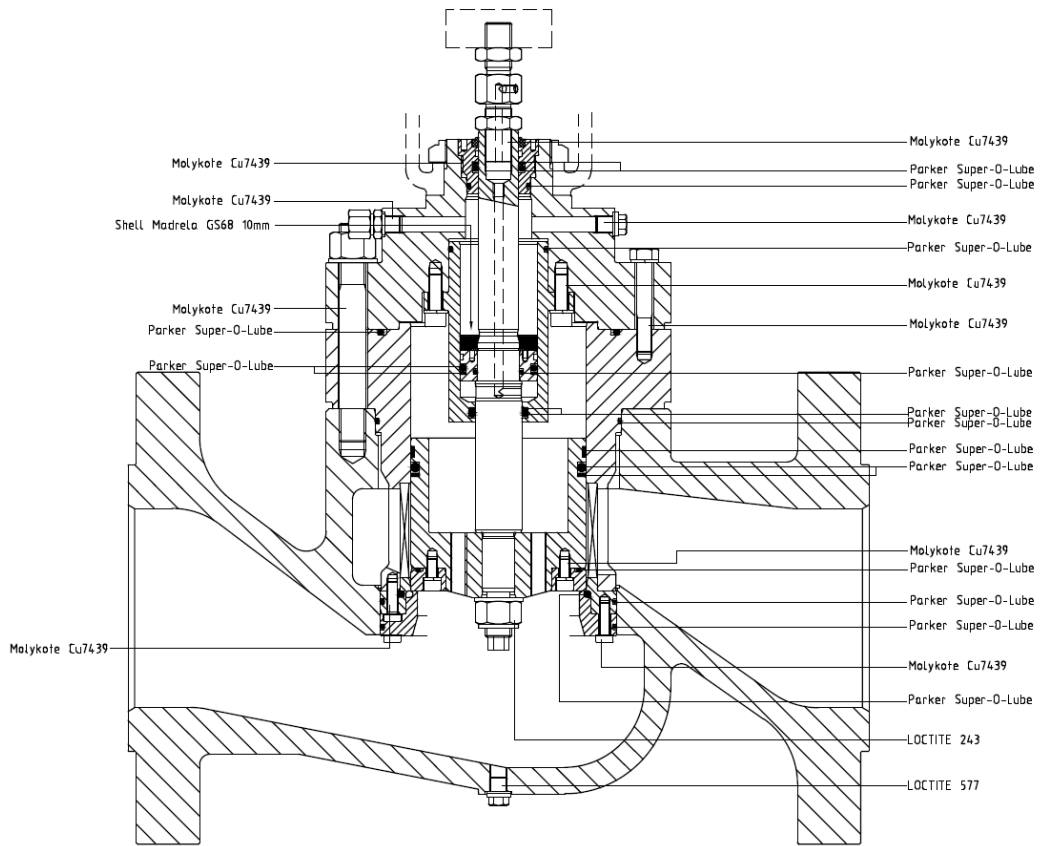

Fig.11 Lubricants and sealants drawing for HON C210S-M

### Recommended bolt preload on pressurized parts:

C210 bolt torque (Nm)			
Size	Pos.		
	16 or 19 or 133	7	130
2"	10	60	
3"	10	75	
4"	10	180	
6"	230	470	
8"	230	450	
10"	230	450	
12"	230	600	
16"	130	780	25

Table 6 Recommended bolt torque for pressure retaining parts

HON C210 series

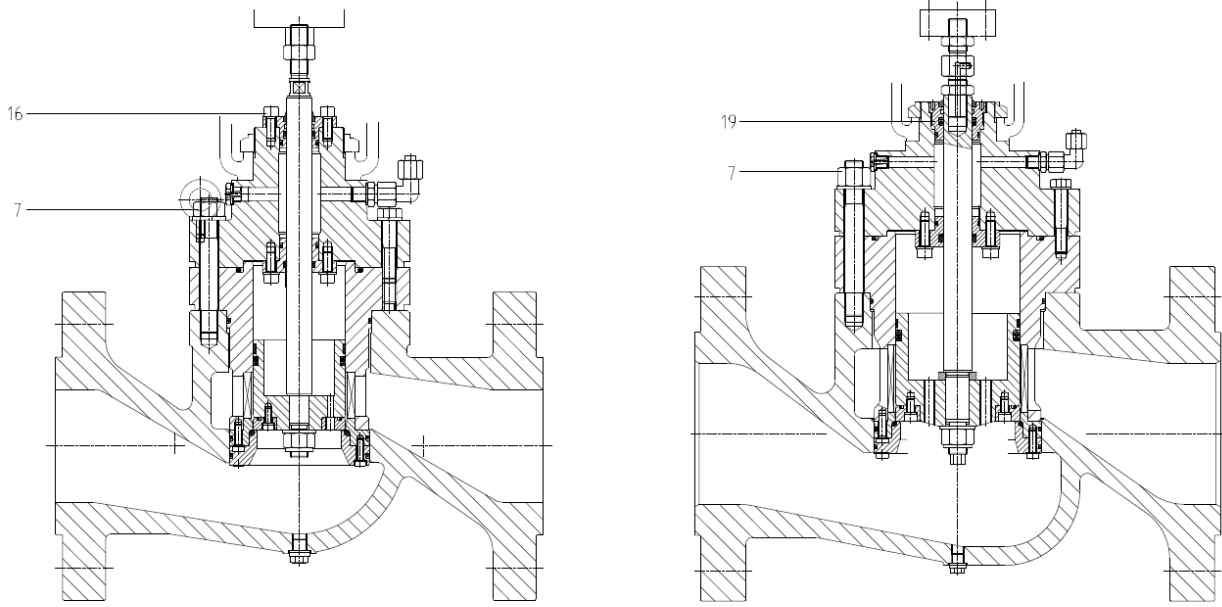

C210S 2"-4" CL150/600

C210S 6"-12" CL150/600

Fig.12 Bolt for pressure retaining parts of HON C210S (M)

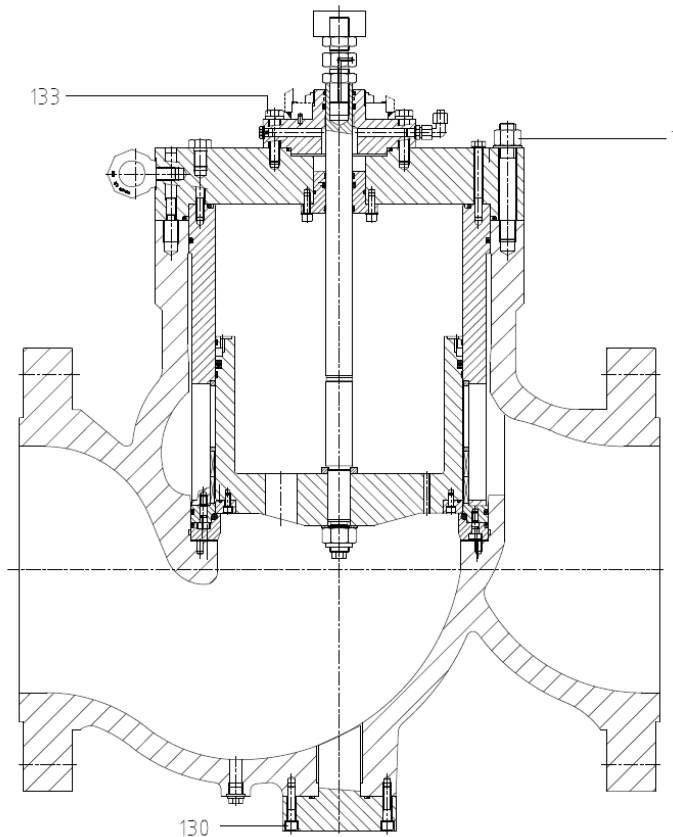

C210S 16" CL150/600

Fig.13 Bolt for pressure retaining parts of HON C210S 16" cl.150/600

### 3.3 Spare-part sets

The spare-part sets can be ordered under following numbers:

Type	Number	Type	Number
HON C210S 2"	939409S161070		
HON C210S 3"	939409S154270	HON C210SM 3"	939409S155960
HON C210S 4"	939409S155950	HON C210SM 4"	939409S155970
HON C210S 6"	939409S154260	HON C210SM 6"	939409S155980
HON C210S 8"	939409S154200	HON C210SM 8"	939409S155990
HON C210S 12"	939409S148270	HON C210SM 12"	939409S156000
HON C210S 16"	939409S180360		

Table 7 spare-part sets of HON C210

## 4. Trouble-shooting

When carrying out maintenance or assembly work on the control valve you are required to relieve the corresponding part of the plant from pressure. It is recommended to drain the pipeline and remove the valve.

### Valve Body

**Important:**  
**The plug seat and plug must be handled very carefully as they can easily be damaged**

#### Plug / Seat

**If the valve does not seal properly, this may be caused by the following reasons:**

- **The tight shut-off is prevented by dirt or other impurities built up between the seat and plug**
- **The sealing edges of the seat and plug are damaged**

Check the plug as follows:

- Provide in a stable working position to check the actuator / bonnet
- Recheck the depressurizing of the valve
- Remove the actuator including bonnet as described in 2.1
- Unscrew the bolts (34) of the sealing ring (36)
- Pull down the sealing ring
- Unscrew the lock nut (37) of the plug (32)
- Pull down the plug using 2x M10-bolts
- Take out the O-rings (29), (33), (35)
- Thoroughly clean guide bushing (28), plug (32) and valve ring (53)
- Replace all damaged parts
- Prior to introducing the parts, apply lubricant (Staburags N32) to all sealing surfaces
- Fasten the lock nut (37) of the plug (32)
- Fasten the bolts (54) of the valve ring (53)

Place the actuator including bonnet as described in 2.1

It is recommended to replace the bonnet sealing (22) and seat sealing (33) while placing the actuator incl. bonnet.

**Note**

Instead of reinstalling the old plug (32, 53) and valve ring (36) insert new ones.

Maybe the old plug and sealing ring can be used again after they have been reworked.

Slight damages on the sealing edges of the plug can be removed by turning and polishing on a lathe.

**Changing the 'seals'**

As the stuffing box consist of an O-ring sealing with a back-up ring and is provided with oil lubrication, maintenance is minimized under normal operation.

If leakage occurs at the valve's 'stuffing box' proceed as follows:

- Provide in a stable working position to disassemble the actuator incl. bonnet
- Recheck the depressurizing of the valve
- Remove the actuator as described in 2.1
- Remove bonnet insert (9) by unscrewing the nuts (7)
- Remove adjusting bolt (50) and nuts (60) from the stem
- Remove bolts (51) and release locking ring (9) from the guiding bush (28)
- Release bonnet (4) from the stem
- Unscrew bolts (11) and release the guiding bush (12)

**Be careful: a small volume of oil will be released**

- Unscrew the guide bush (19) from the bonnet (4)
- Remove the valve ring (36) by unscrewing the bolts (34)
- Unscrew nut (38) and remove valve (32), use 3xM10 bolts
- Remove valve ring (53) by unscrewing the bolts (54)
- Be careful not to damage the stem (2)

**Check all parts, and replace all damaged parts**

Prior to introducing the parts, apply lubricant (Staburags N32) to all sealing surfaces.

Assemble in the same sequence (bottom-top) as described.

Finally add oil as described in 4.2

HON C210 series

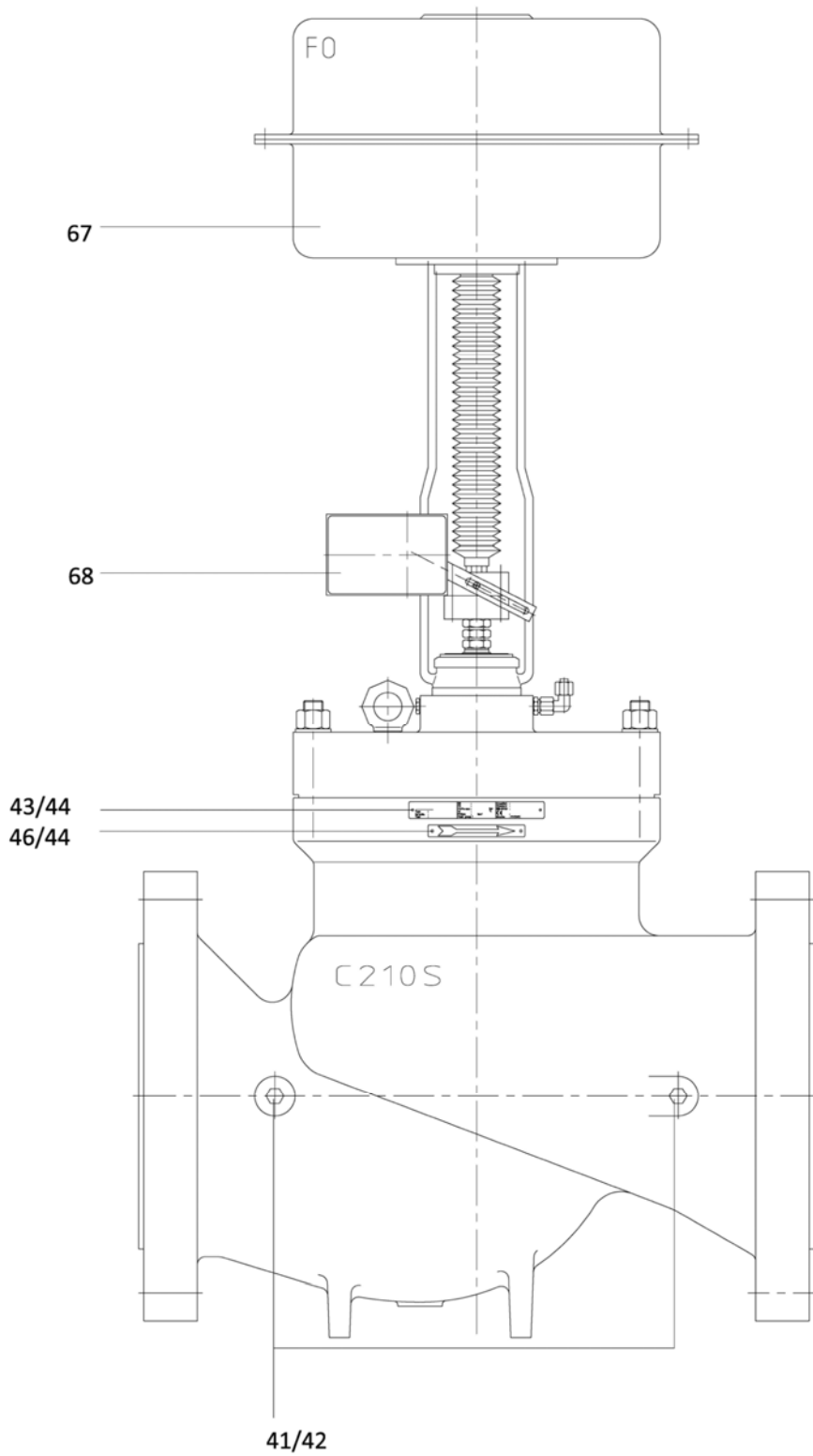

Fig. 14a Drawing of Model HON C210S



HON C210 series

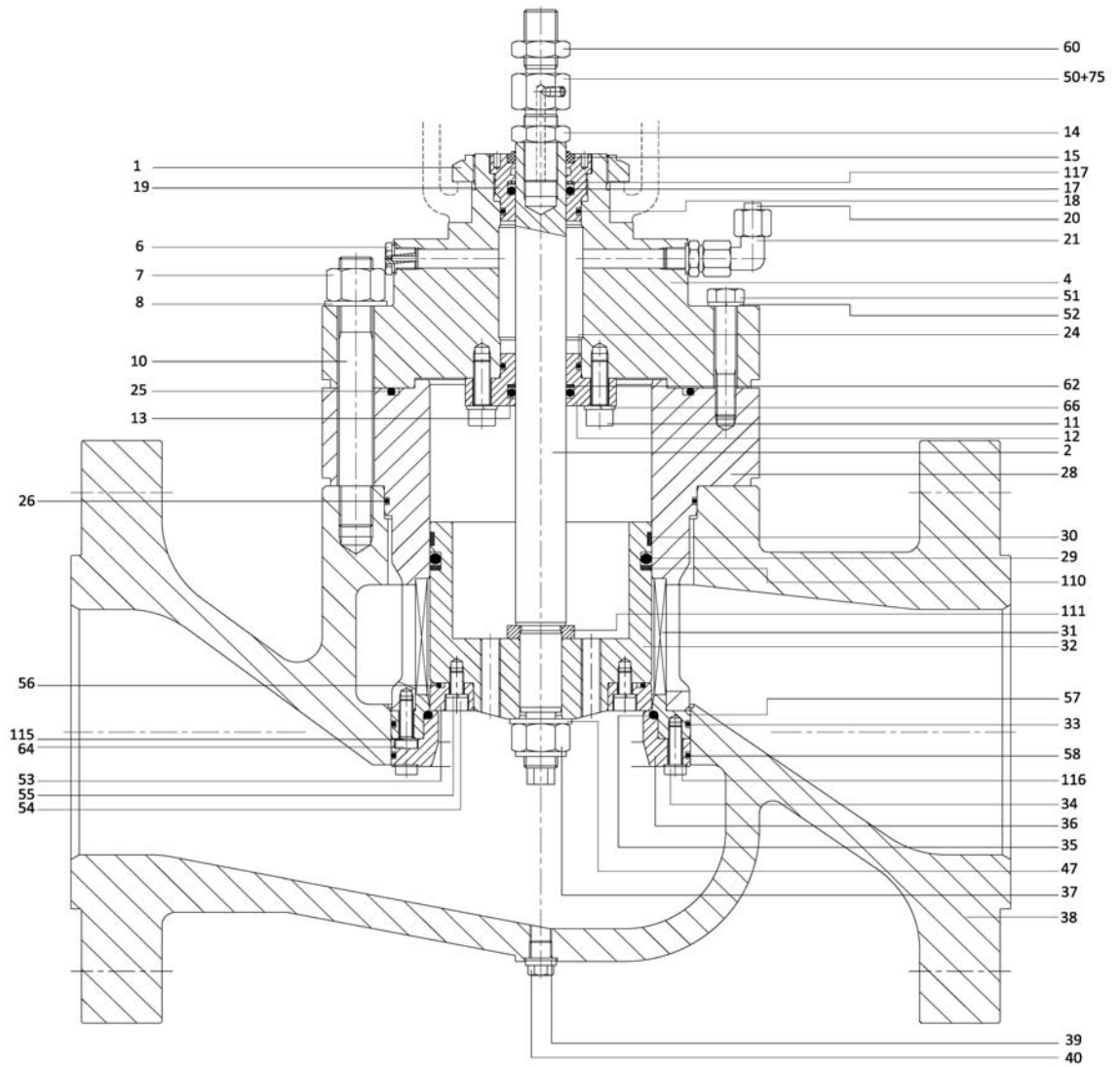

Fig. 14b Sectional drawing of HON C210S 6"150/600

<b>HON C210S parts list example</b>					
Pos.	Description		Pos.	Description	
2	plug stem		38	valve body	
4	bonnet		39	sealing washer	
6	plug		40	plug	
7	nut		43	name plate	
8	washer		44	drive screw	
10	stud		46	winker	
11	socket head screw		47	washer	
12	lower guidance		48	plug	
13	o-ring	*	49	sealing washer	
14	nut		50	stem adapter	
15	dirt wiper	*	51	socket head screw	
17	o-ring	*	52	spring washer	
18	o-ring	*	53	valve ring	
19	upper guidance		54	socket head screw	
20	plug		55	spring washer	
21	coupling		56	o-ring	*
24	o-ring	*	57	locking ring	
25	o-ring	*	58	o-ring	*
26	o-ring	*	60	nut	
28	guide bush		62	back-up ring	*
29	o-ring	*	64	socket head screw	
30	strip	*	65	hoisting eye	
31	silencer		66	spring washer	
32	valve		75	restriction	
33	o-ring	*	110	back-up ring	*
34	socket head screw	*	111	thrust washer	
35	o-ring	*	115	sealing washer	*
36	seal retainer		116	sealing washer	*
37	Self-locking nut	*	117	back-up ring	*

Table 8 parts list of HON C210S 6" 150/600

**The with \* marked parts are recommended spare parts**

HON C210 series

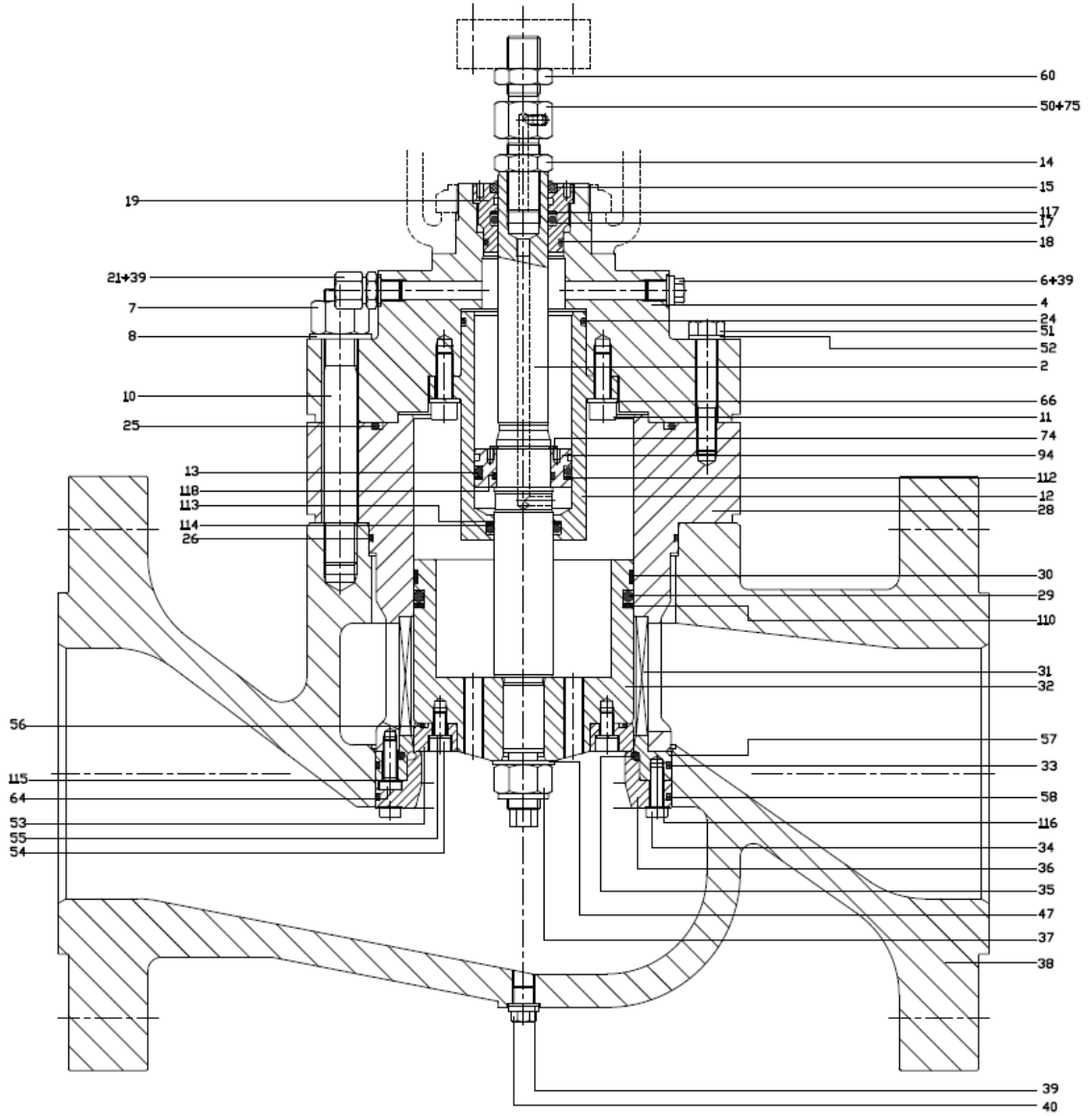

Fig. 14c Sectional drawing of HON C210SM 6"150/600

HON C210SM Parts List example 6"					
Pos.	Description		Pos.	Description	
2	plug stem		40	plug	
4	bonnet		43	name plate	
6	plug		44	drive screw	
7	nut		46	winker	
8	washer		47	washer	
10	stud		48	plug	
11	socket head screw		49	sealing washer	
12	lower guidance		50	stem adapter	
13	o-ring	*	51	socket head screw	
14	nut		52	spring washer	
15	dirt wiper	*	53	valve ring	
17	o-ring	*	54	socket head screw	
18	o-ring	*	55	spring washer	
19	upper guidance		56	o-ring	*
21	coupling		57	locking ring	
24	o-ring	*	58	o-ring	*
25	o-ring	*	60	nut	
26	o-ring	*	64	socket head screw	
28	guide bush		65	hoisting eye	
29	o-ring	*	66	spring washer	
30	strip	*	74	Circlip	
31	silencer		75	restriction	
32	valve		94	Compensation plunger	
33	o-ring	*	110	back-up ring	*
34	socket head screw	*	112	back-up ring	*
35	o-ring	*	113	back-up ring	*
36	seal retainer		114	o-ring	*
37	Self-locking nut	*	115	sealing washer	*
38	valve body		116	sealing washer	*
39	sealing washer		117	back-up ring	*
			118	o-ring	*

Table 9 parts list of HON C210SM 6" 150/600

**The with \* marked parts are recommended spare parts**

HON C210 series

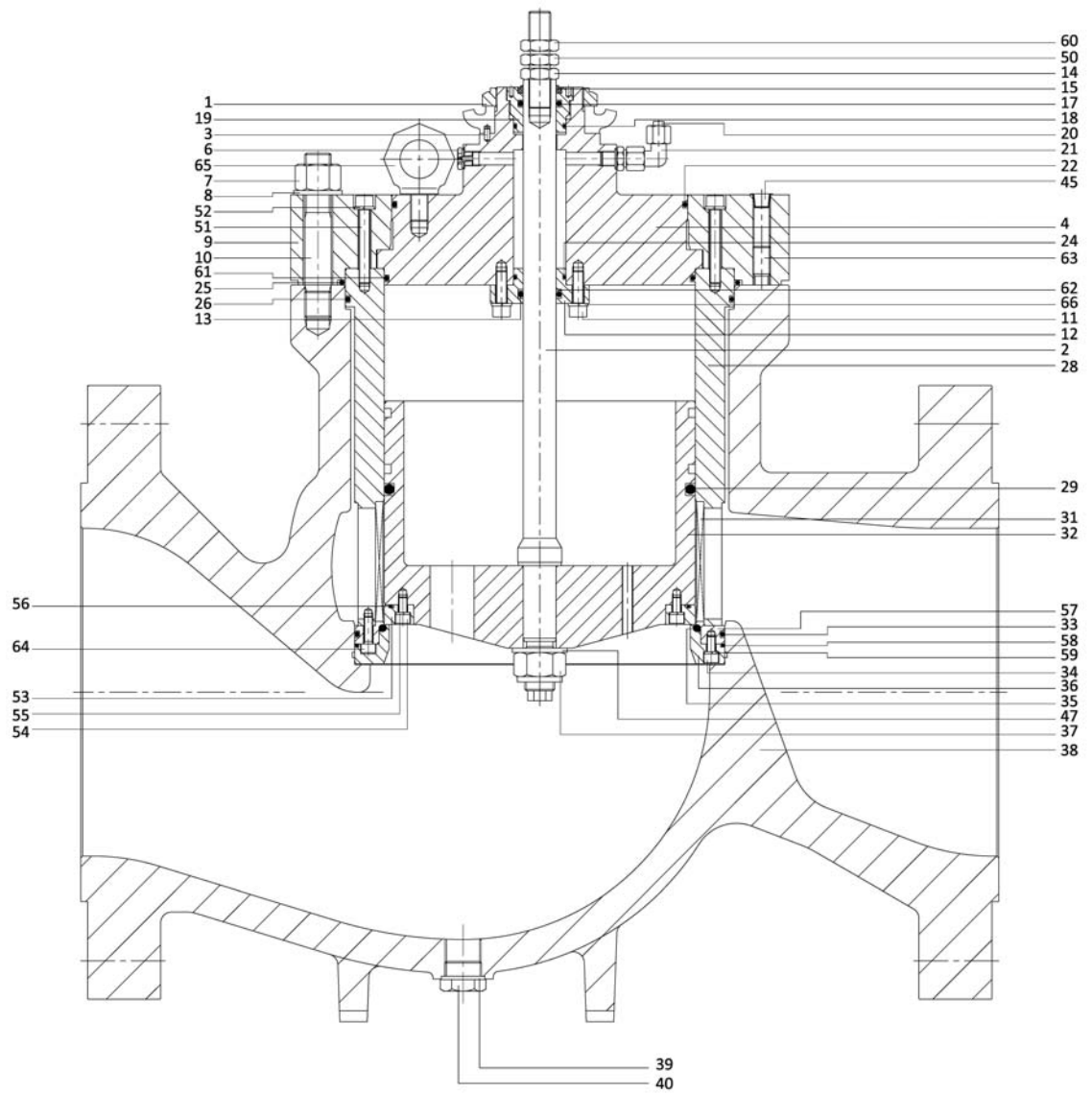

Fig. 14c Sectional drawing of HON C210S 12"150/600

HON C210S Parts List example 12"					
Pos.	Description		Pos.	Description	
2	plug stem		37	Self-locking nut	*
3	pin		38	valve body	
4	bonnet		39	sealing washer	
6	plug		40	plug	
7	nut		41	sealing washer	
8	washer		42	plug	
9	locking ring		43	name plate	
10	stud		44	drive screw	
11	socket head screw		45	dirt plug	
12	lower guidance		46	winker	
13	o-ring	*	47	washer	
14	nut		50	stem adapter	
15	dirt wiper	*	51	socket head screw	
17	o-ring	*	52	spring washer	
18	o-ring	*	53	valve ring	
19	upper guidance		54	socket head screw	
20	plug		55	spring washer	
21	coupling		56	o-ring	*
22	o-ring	*	57	locking ring	
24	o-ring	*	58	o-ring	*
25	o-ring	*	59	spring washer	
26	o-ring	*	60	nut	
28	guide bush		61	o-ring	*
29	o-ring	*	62	back-up ring	*
31	silencer		63	Set screw hex. socket	
32	valve		64	socket head screw	
33	o-ring	*	65	hoisting eye	
34	socket head screw	*	66	spring washer	
35	o-ring	*	115	sealing washer	*
36	seal retainer		117	back-up ring	*

Table 10 parts list of HON C210S 12" 150/600

**The with \* marked parts are recommended spare parts**

HON C210 series

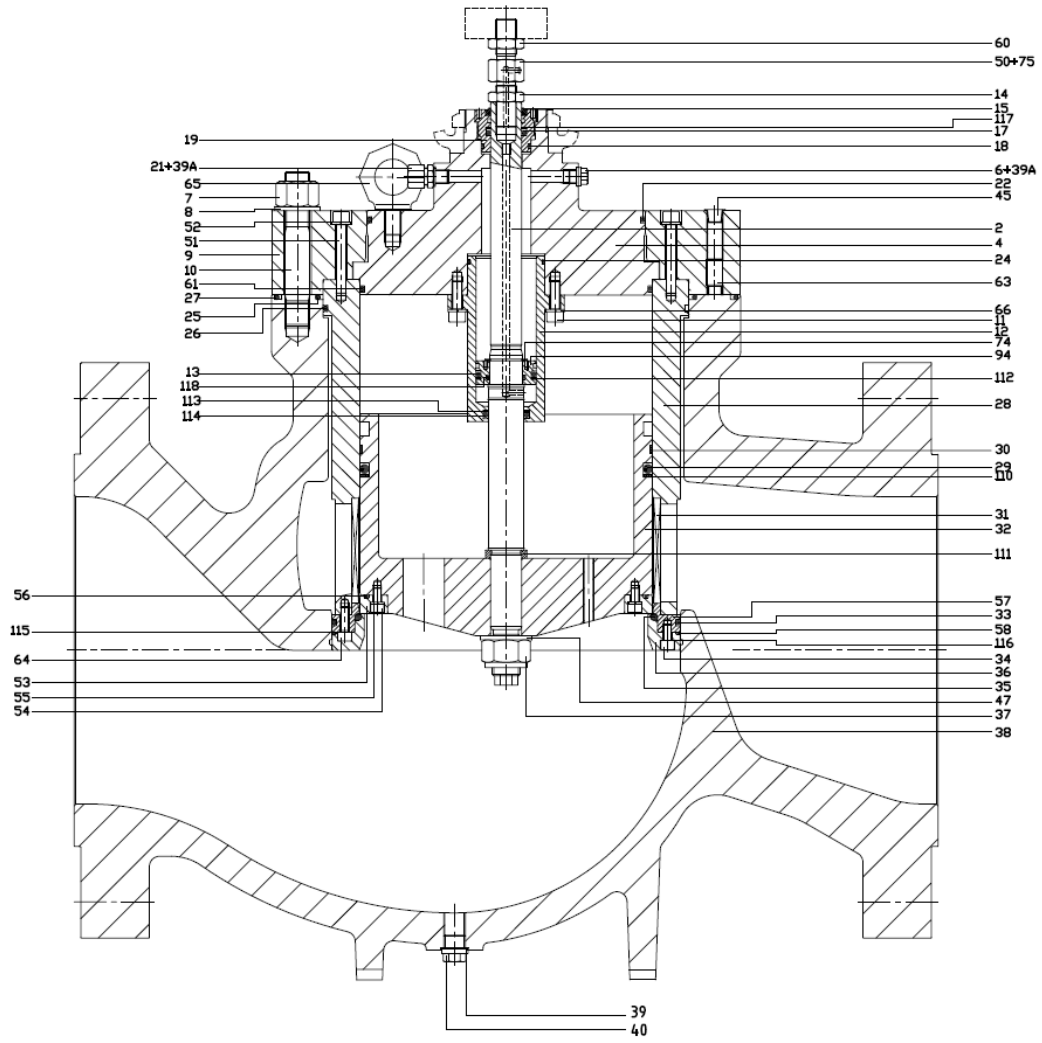

Fig. 14D Sectional drawing of HON C210SM 12"150/600

HON C210SM Main Parts List example 12"					
Pos.	Description		Pos.	Description	
2	plug stem		40	plug	
4	bonnet		43	name plate	
6	plug		44	drive screw	
7	nut		46	winker	
8	washer		47	washer	
10	stud		48	plug	
11	socket head screw		49	sealing washer	
12	lower guidance		50	stem adapter	
13	o-ring	*	51	socket head screw	
14	nut		52	spring washer	
15	dirt wiper	*	53	valve ring	
17	o-ring	*	54	socket head screw	
18	o-ring	*	55	spring washer	
19	upper guidance		56	o-ring	*
21	coupling		57	locking ring	
24	o-ring	*	58	o-ring	*
25	o-ring	*	60	nut	
26	o-ring	*	64	socket head screw	
28	guide bush		65	hoisting eye	
29	o-ring	*	66	spring washer	
30	strip	*	74	Circlip	
31	silencer		75	restriction	
32	valve		94	Compensation plunger	
33	o-ring	*	110	back-up ring	*
34	socket head screw	*	112	back-up ring	*
35	o-ring	*	113	back-up ring	*
36	seal retainer		114	o-ring	*
37	Self-locking nut	*	115	sealing washer	*
38	valve body		116	sealing washer	*
39	sealing washer		117	back-up ring	*
			118	o-ring	*

Table 11 parts list of HON C210SM 12" 300/600

**The with \* marked parts are recommended spare parts**